

EASYSENSE V-Log Reference Manual



CONTENTS

What's supplied?.....3
 Getting to know your V-Log data logger3
 The V-Log data logger4
 V-Log buttons4
 Sensors4
 The plug-in sensors4
 V-Log 8's built-in sensors5
 Changing a sensors range and turning a sensor on or off6
 Ways to capture data6
 Using V-Log standalone (without a computer).....7
 Meter7
 Pictogram.....8
 EasyLog9
 Snapshot..... 11
 Timing 11
 Counting..... 16
 Review 17
 System 17 - 19
 (Switch Off, Sensor (changing range or turning on or off), Delete Data, Full Reset, Language, Date Style, Decimals, Meter Text)
 Technical information..... 19
 Selecting the sensor range 19
 Powering V-Log 20
 Batteries..... 20
 Auto switch off 20
 Internal Clock and Calender 21
 V-Log's memory..... 21
 Hard Reset 21
 Full Reset..... 21
 Specifications 21
 Care & Maintenance 22
 Updating EASYSSENSE V-Log's Firmware 23
 Using V-Log connected via USB lead to Windows PC for the first time 23
 V-Log in WiFi mode 26
 Connecting V-Log WiFi to a network 26
 V-Log Access Point connection using the default settings 26
 Connecting V-Log to a school's network (Infrastructure) 27
 To connect back to an Access Point network 27
 To change the name of the Access Point network 27
 To encrypt the Access Point network 27
 To make V-Log forget a known WiFi network..... 28
 To change V-Log's name..... 28
 To reset WiFi to its default settings 28
 Connecting a group of iPads/Androids to a V-Log 28
 Setup WiFi menu 29
 V-Log in Bluetooth mode 29
 When connecting to a Windows computer 29
 When connecting to a iPad or Android device..... 30
 Limited Warranty..... 31

Copyright: all rights reserved.

This manual may be copied for use within the premises of the Licensee on condition that it is not loaned, sold or used outside the Licensee's premises.

Data Harvest's policy is to continually improve products and services, so we reserve the right to make changes without notice. It is acknowledged that there may be errors or omissions in this publication for which responsibility cannot be assumed. No liability will be accepted for loss or damage resulting from use of information contained in this manual or from uses as described.

What's supplied?



Getting to know your V-Log data logger

Charge EASYSense V-Log fully before first use

Connect V-Log directly to a USB port on your computer*, or a powered USB hub, or a USB mains charger that outputs 5 V at 1 A or more, using the USB cable supplied. A full charge can take up to 8 hours.

A battery charging symbol will be displayed on V-Log's screen while the logger is charging.

*Your computer must be turned on and not in sleep or standby mode; otherwise the battery may drain instead of charge.

The V-Log data logger

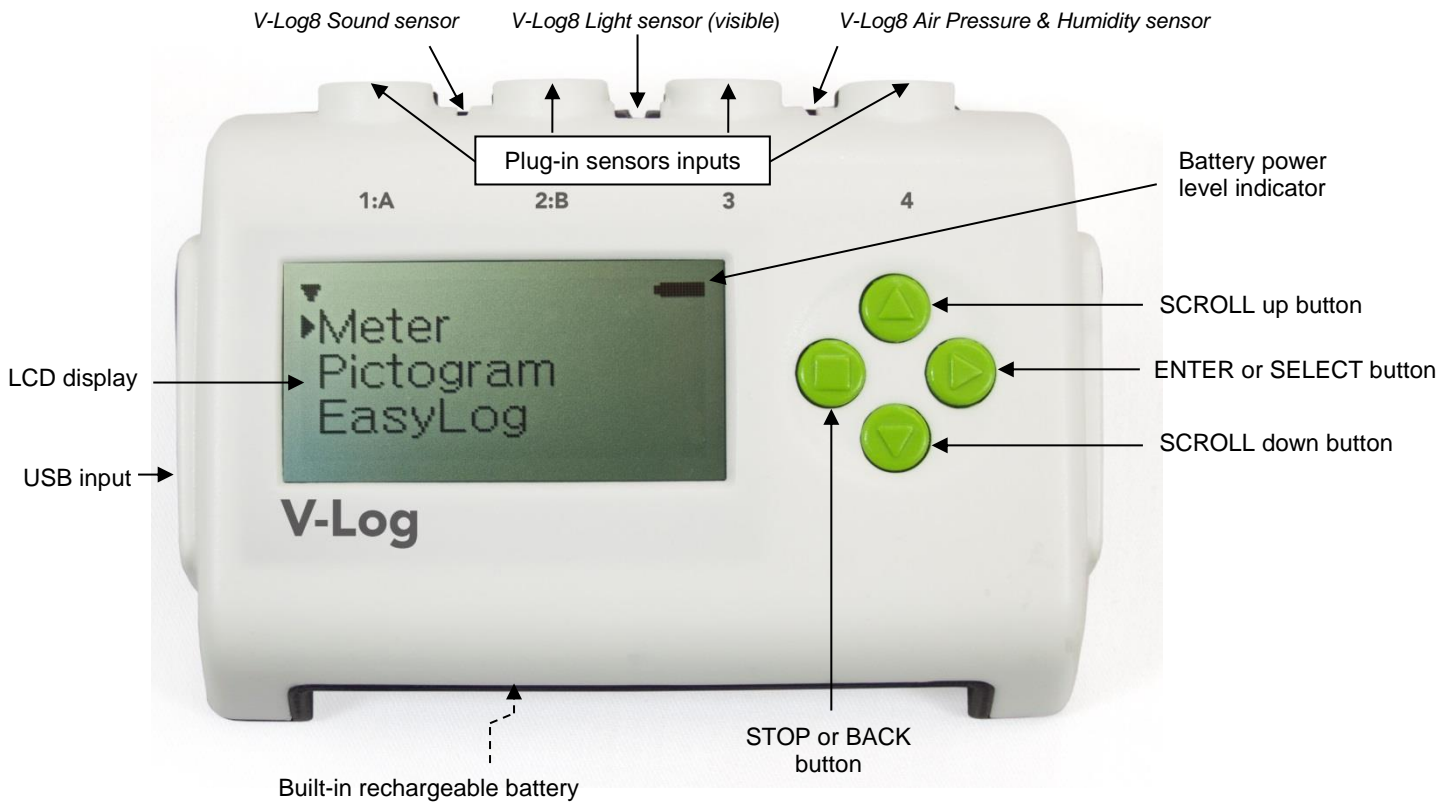

V-Log buttons



The ENTER button is used to start data collection, progress to the next screen, confirm a choice or take a sample.



The square STOP button is used to stop data being recorded or return to the previous screen.



The SCROLL buttons are used to scroll through menus on the LCD screen or to browse measurements during data logging.

Sensors

The plug-in sensors

Smart Q Sensors are available to purchase separately and are **not** supplied with V-Log.

Sensors can be divided into two main types:

1. Analogue - used to measure physical quantities such as temperature, sound, light, pH, etc.
2. Digital - switch-type sensors for measuring ON/OFF conditions e.g. Light gates and Timing mats to calculate time, speed and acceleration.







Please contact your supplier or the Data Harvest website (www.data-harvest.co.uk) for up-to-date information on Smart Q sensors.

Plug the Smart Q sensors into the shaped input sockets on the top of the logger using the leads supplied with the logger. When a sensor is connected it will automatically be detected and displayed on the LCD display.

Sensor inputs 1 and 2 are dual labelled as A and B. These inputs are for Timing operations when digital sensors must be connected to either input 1:A or input 1:A and 2:B.

V-Log 8's built-in sensors

The V-Log 8 has 4 built-in sensors – Sound, Light, Humidity and Air Pressure.

	Built-in Sensors	Ranges
	Sound	40 to 110 dBA ±2000 mV
	Light level	Indoor (Slow) 1 k lx (0 to 1,000 lx) Indoor (Fast) 1 k lx (0 to 1,000 lx) In/Out 10 k lx (0 to 10,000 lx) Outdoor 100 k lx (0 to 100,000 lx)
	Humidity	0 to 100% RH
	Air Pressure	85 to 110 kPa 850 to 1100 mbar 25 to 33 inHg -200 to 1,000 m -500 to 5,000 m -500 to 10,000 m

The **Sound sensor** has two ranges:

- **Decibel range** (40 to 110 dBA) used to measure sound pressure level (loudness). It is responsive to both single sounds (such as a whistle or handclap) and continuous background noise (such as passing traffic, classroom noise).
- **Millivolt range** (±2000 mV) used when examining the frequency content of sound e.g. sound waves: monitoring the effect of altering frequency and amplitude, wave forms of musical instruments, beat patterns, etc.

The **Light level sensor** has 4 ranges:

- **Indoor (slow) 1 k lx.** This lower range is suitable for recording at indoor light levels and so is normally selected for use in the classroom.
- **Indoor (fast) 1 k lx.** Unlike the other ranges this low range is unfiltered and so has a fast linear response. It can monitor rapid variations in light intensity, which cannot be observed with the eye e.g. fluctuations in the light intensity of a bulb due to voltage fluctuation.
- **In/Out 10 k lx.** This medium range is suitable for recording bright light levels indoors or low light levels outdoors.
- **Outdoor 100 k lx.** This large range makes it ideal for outdoor use (sunlight) and environmental monitoring.

The **Humidity sensor** has one range, 0 to 100%. The sensor is used to monitor relative humidity i.e. the amount of water actually in the air compared with the amount of vapour needed to make the air saturated at the air's current temperature.

The response time of a humidity sensor varies considerably with air circulation; therefore the speed of reaction to change in humidity will be delayed by V-Logs plastic case.

The **Pressure sensor** is used to measure **barometric** pressure or **altitude** in meters above sea level.

- For barometric pressure readings use either the kPascals range (85 to 110 kPa) or its equivalent in millibar (850 to 1100 mbar) or inches of mercury (23 to 33 inHg)
- For altitude in meters above sea level use either the -200 to 1,000 m, -500 to 5,000 m or -500 to 10,000 m range.

The average pressure exerted at sea level by the atmosphere in Britain is 101.325 kPa (1 atmosphere); the equivalent values are 29.92 inches of mercury (at 0°C) or 1013 millibar.

Changing a sensors range and turning a sensor on or off

- Use the up or down buttons (▲ & ▼) to scroll until the cursor is pointing at **Meter** and press enter ►.
- Press the enter ► button again.
- Use the up or down buttons (▲ & ▼) to scroll until the cursor is pointing at the appropriate sensor and press enter ►.
- Use the up or down buttons (▲ & ▼) to scroll until the cursor is pointing at the appropriate option and press enter ►.

Note: If a sensor only has one range then only Turn Off will be available.

Set range

The cursor will indicate the current range selected.

Use the up or down buttons (▲ & ▼) to scroll until the cursor is pointing at the required range. Press enter ► to select that range.

Select ■ to exit the sensor option window. Select ■ to return to the Meters window

Turning a sensor ON or OFF the display

V-Log 8's built-in sensors can be switched On or Off the display.

With the cursor pointing at Turn Off / On press enter ► to alter from Off to On or vice versa.

Select ■ to return to the Meters window.

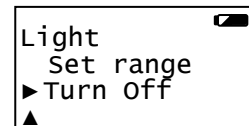
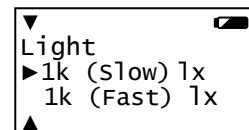
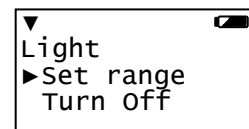
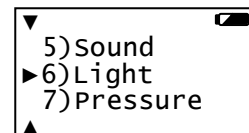
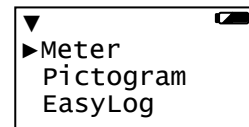

Note: If you change a sensor's range or turn it on/off via the logger while connected to a computer, it may be necessary to select New  in the software for these changes to be detected.

Ways to capture data

There are different ways that V-Log can be used to collect data.

1. As a stand-alone instrument: V-Log is used to display, collect and store data while disconnected from the computer i.e.
 - a. Display readings on its LCD screen (but not stored) using **Meter** mode.
 - b. Display, collect and store data using V-Log's logging menu options e.g. **Pictogram**, **EasyLog**, **Snapshot**, **Timing** and **Counting**.

The data collected is stored in V-Log's memory to either be reviewed on V-Log's screen or retrieved to the EasySense software on a computer.

Up to 255 sets of data can be stored in V-Log's memory.

- As an interface connected to a computer: V-Log is entirely driven by the software on the host computer. The data from the sensors is transmitted immediately to the computer and displayed on the computers screen using the options in the EasySense software. This method of collection is useful for many classroom-based experiments.

Using V-Log standalone (without a computer)

To switch V-Log on, press any button on the panel.

Notes:

- If V-Log is operating on battery power and is idle, it will automatically switch itself **off** after 2 minutes. Press any button to resume operation.
- V-Log does not auto switch off while powered from a USB port.

V-Log has a menu of different options available, which are displayed on the built-in LCD screen.

There are six working modes, which can be used to collect data without being connected to the computer. These are **Meter**, **Pictogram**, **Easy Log**, **Snapshot**, **Timing** and **Counting** modes.

A menu option is selected by using the up and down buttons (▲ & ▼) to scroll the cursor until it is pointing at the required option then press enter ► to select.

If using plug-in sensors they should be connected before entering a logging mode (except for Meters when they will automatically be detected and then display readings).

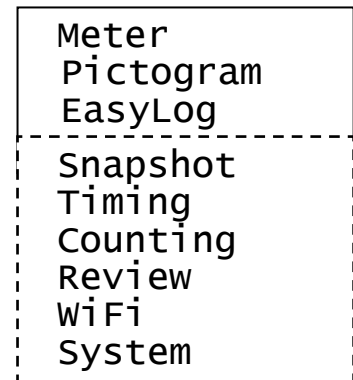

Meter

In Meter mode V-Log will display measurements from the sensors (plug-in or built-in sensors) on the LCD screen but will not store any data.

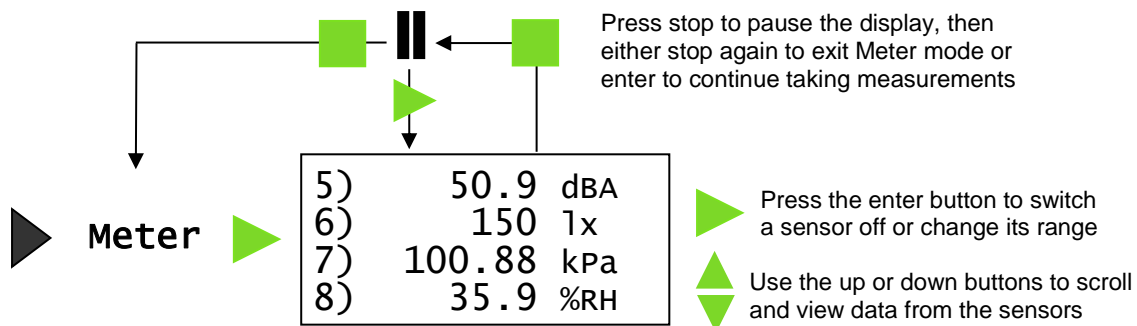

The size of the text in Meter mode can be altered. From the **System** menu select **Meter Text** then either **Single Height** or **Double Height**. With double height selected data from up to 4 sensors is visible on the screen (scroll to see more). If single height is selected then the data from up to 8 sensors is visible.

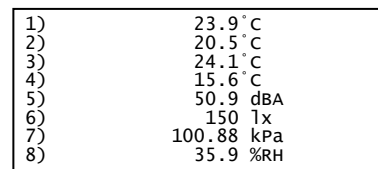

- Connect any plug-in sensors if required. If the display is turned off, press any button to wake up the logger
- While in the main menu use the up or down buttons ▲ ▼ to scroll until the cursor is pointing at **Meter**. Press the enter button ► to select.
 - Use the up and down buttons ▲ ▼ to view data from the sensors.
 - Use the enter button ► to check or change the sensors range or to switch a sensor off.
 - The stop button ■ will temporarily halt the updates to the sensors readings. Two lines ■■ (top left) indicate that the display is paused.

Press enter ► to cancel pause and continue in Meters. Press stop ■ again to exit Meters and return to the main menu.

Pictogram

Pictogram uses an image, block or bar to represent the data. Each represents a 10th of a total range (or span) of the sensor and displays a number from zero to ten (proportional to the reading).

Sensor readings are captured every time ► is pressed, rather than at regular time intervals. Up to 10 samples can be stored in each set of data.

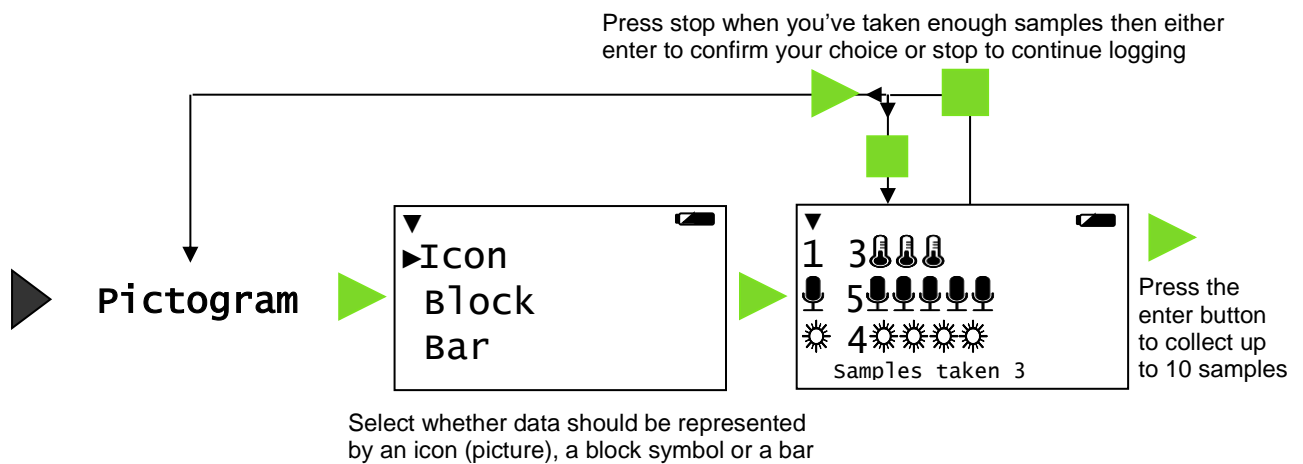

1. Connect any plug-in sensors if required. If the display is turned off, press any button to wake up the logger.
2. While in the main menu use the up or down buttons ▲ ▼ to scroll until the cursor is pointing at **Pictogram**. Press the enter button ► to select.

3. Use the up or down buttons ▲ ▼ to move the cursor until it points at how you want the data to be represented. Press the enter button ► to select.

4. Each time you press the enter button ► V-Log will take a reading from the sensors (built-in and any plug-in) and will show the number of samples taken so far.

Use the up or down buttons ▲ ▼ to scroll and view data from the sensors.

Note: If V-Log goes into 'sleep' mode during logging, press any button to wake up the logger and then press ► to take a reading.

5. When you have finished sampling press the stop button ■ to close the data set, then ► to confirm your choice.

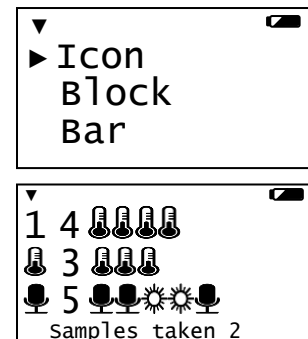

The readings will be stored as a data set with a maximum of ten samples per set.

A data set is identifiable by the method and time and date the recording was started e.g. Pictogram 09/08/14 16:12:43.

The contents of the data set can be:

- Reviewed on V-Log: select **Review** from the main menu, use the ▲ ▼ buttons to locate the data set and press enter ► to select. Use the ▲ ▼ buttons to scroll through individual readings (see [page 17](#)).
- Downloaded to a computer by selecting **Remote ► Retrieve Remote** from the Home screen in the EasySense software.



Key for built-in sensors

Sensor	Sound 40 to 110 dBA	Sound ± 2000 mV	
Scale (10 th of range)	7 dBA	400 mV	
Sensor	Light 0 to 1 k lx	Light 0 to 10 k lx	Light 0 to 100 k lx
Scale (10 th of range)	100 lx	1,000 lx	10,000 lx
Sensor	Humidity 0 to 100%		
Scale (10 th of range)	10 %		
Sensor	Air Pressure in kPa 85 to 110 kPa	Air Pressure in mbar 850 to 1100 mbar	Air Pressure in inHg 25 to 33 inHg
Scale (10 th of range)	2.5 kPa	25 mbar	0.8 inHg
Sensor	Air Pressure (Altitude) -200 to 1,000 m	Air Pressure (Altitude) -500 to 5,000 m	Air Pressure (Altitude) -500 to 10,000 m
Scale (10 th of range)	120 m	550 m	1050 kPa

EasyLog

With EasyLog it is not necessary to set the duration of the recording – V-Log will capture data until stopped. The bottom line of the LCD display is a visual indicator of logging as it takes place, each time the line completes the logged samples are compressed and the sample rate alters.

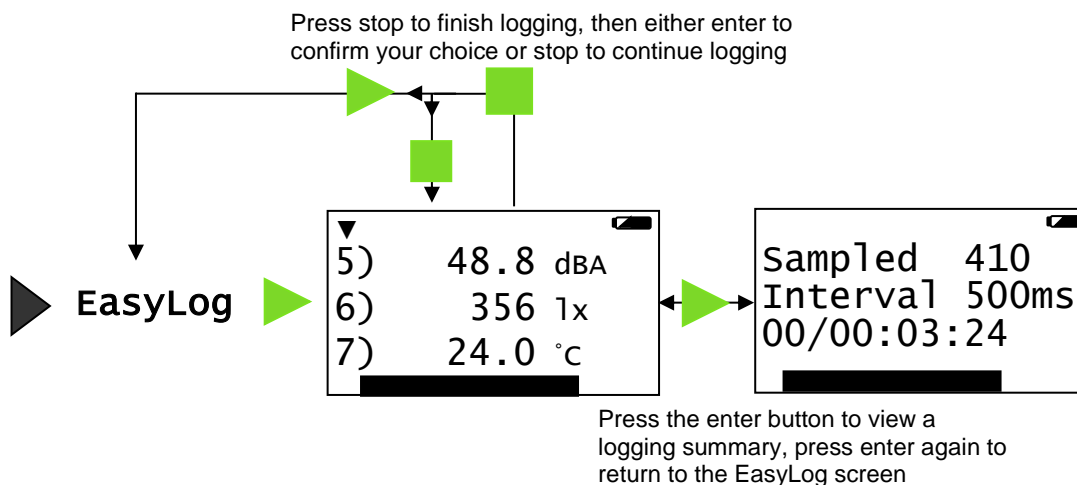



1. Connect any plug-in sensors if required. If the display is turned off, press any button to wake up the logger.
2. While in the main menu use the up or down buttons ▲ ▼ to scroll until the cursor is pointing at **EasyLog**. Press the enter button ► to automatically begin logging.

If using more than 3 sensors use the ▲ ▼ buttons to view the current value while still logging.

The bottom line of the LCD display is a visual indicator of logging as it takes place, each time the line completes logged samples are compressed and the sample rate alters.







Press the enter ► button to see a logging summary i.e. samples taken, current logging interval and the elapsed time (days / hours: minutes: seconds). Press enter ► again to return to the normal screen.

Note: If V-Log goes into 'sleep' mode during logging, any button press will wake up the logger.

- When the investigation is complete press the stop button . V-Log will continue to log data until you press the enter  button to confirm your choice

The data will be stored as a data set identifiable by the method and time and date the recording was started i.e. EasyLog 09/05/14 16:12:43.

The contents of the data set can be

- Reviewed on V-Log - select **Review** from the main menu, use the   buttons to locate the data set, press enter  to select. Use the   buttons to scroll through individual readings (see page 17).
- Downloaded to a computer by selecting **Remote**  **Retrieve Remote** from the Home screen in the EasySense software.

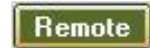

V-Log records data at a rate of 40 samples per second until it has captured 1,000 samples. At this point the sample rate halves (i.e. 20 samples per second) and alternate samples are discarded (leaving 500 samples). It will continue at this speed until it has captured another 500 samples (1,000 in total) then the sample rate halves (i.e. 10 samples per second) and discards half the stored data, and so on.

Sample Rate	Interval (seconds)	Samples	Days	Hours	Min.	Sec.
40 per sec	0.025 (25 ms)	0 - 1000				25
20 per sec	0.05 (50 ms)	Compress to a half 500 - 1000				50
10 per sec	0.1 (100 ms)	Compress to a half 500 - 1000			1	40
2 per sec	0.5 (500 ms)	Compress to a fifth 200 - 1000			8	20
1 per sec	1	Compress to a half 500 - 1000			16	40
Every 5 sec	5	Compress to a fifth 200 - 1000		1	23	20
Every 15 sec	15	Compress to a third 330 - 1000		4	10	0
Every 30 sec	30	Compress to a half 500 - 1000		8	20	0
Every 1 minute	60	Compress to a half 500 - 1000		16	40	0
Every 5 minutes	300	Compress to a fifth 200 - 1000	3	11	20	0
Every 15 minutes	900	Compress to a third 300 - 1000	10	10	0	0
Every 30 minutes	1800	Compress to a half 500 - 1000	20	20	0	0
Every 1 hour	3600	Compress to a half 500 - 1000	41	16	0	0

While battery powered V-Log will stay awake until the interval between readings reaches 5 seconds or greater – at this point it will begin to sleep (auto switch off) between samples to conserve battery power. When V-Log is asleep, sensor readings can be viewed by pressing any button to ‘wake’ it up.

Note: V-Log does not auto switch off when accepting power from the USB port.





When the sample interval is greater than or equal to one second (after logging for 8 minutes and 20 seconds), it is possible to download data from V-Log to a computer to check its validity (without interrupting the recording) using **Retrieve Remote** in the EasySense software.

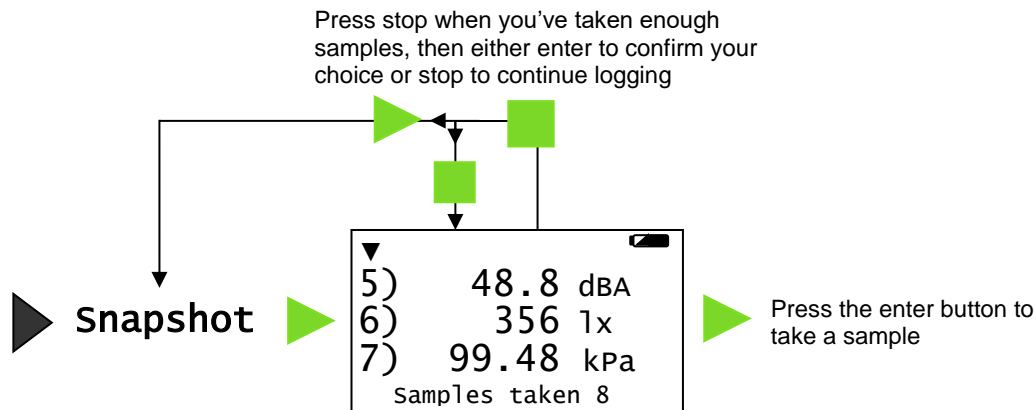

Note: If you would prefer to record remotely for a specified time span use **Remote**  **Setup Remote** from the Home screen in the EasySense software.

Snapshot



Snapshot mode enables you to capture sensor readings every time the enter button  is pressed, rather than at regular time intervals.



1. Connect any plug-in sensors if required. If the display is turned off, press any button to wake up the logger.
2. While in the main menu use the up or down buttons   to scroll until the cursor is pointing at **Snapshot**. Press the enter button  to select.
3. Each time you press the enter button  a reading will be taken from the sensors. The bottom line of the LCD will display the number of samples taken so far.





If using more than 3 sensors use the   buttons to view the current value from the sensors while still logging.

Note: If V-Log goes into 'sleep' mode during logging, press any button to wake up the logger then press  to take a reading.

4. When you have finished sampling press the stop button  to close the data set, then enter  to confirm your choice.

The readings will be stored as a data set identifiable by the method and time and date the recording was started i.e. Snapshot 09/05/12 16:12:43. At least 650 samples can be stored in one data set (the limit is dependent on the number of sensors).

The contents of the data set can be

- Reviewed on V-Log - select **Review** from the main menu, use the   buttons to locate the data set, press enter  to select. Use the   buttons to scroll through individual readings (see page 17).
- Downloaded to a computer by selecting **Retrieve** ► **Retrieve Remote** from the Home screen in the EasySense software.



Timing

Timing is used to set up and store simple time and speed measurements using digital switch type sensors. Connect either one sensor to Input 1:A or two to Input 1:A and 2:B before selecting Timing. The options available will depend on whether one or two sensors are connected.

For V-Log to be able to calculate speed or acceleration you will need to enter a measurement of the apparatus used in the experiment e.g.

- For Speed A to B this is the distance between the sensor connected to input A and the sensor connected to input B (0.10 m to 6.00 m in steps of 0.10 m).

$$\text{Speed from A to B} = \frac{\text{Distance from A to B}}{\text{Time}}$$

- For Speed at A, using a single interrupt card, select the width of the card that will pass through the Light gate (30 mm to 120 mm).

$$\text{Speed at A} = \frac{\text{Length of single interrupt card}}{\text{Time}}$$

Upon completion of a timing event the measurement will be displayed on the LCD display.

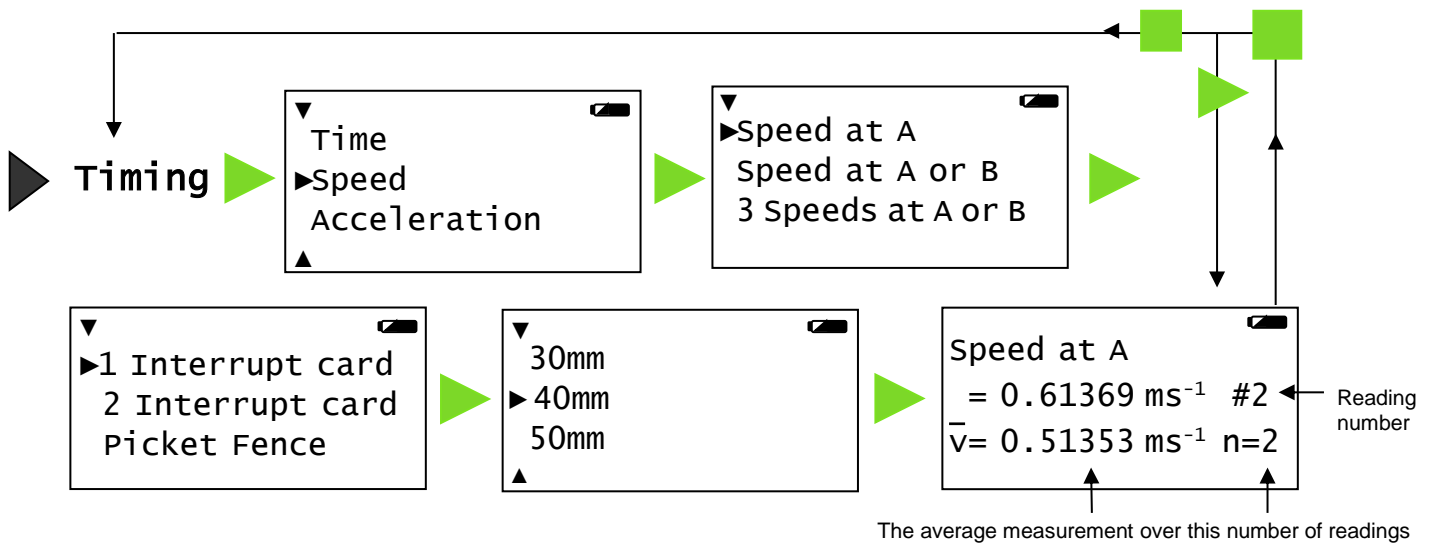

- Either connect a digital sensor to input A or a pair of digital sensors to Input A and B. If the display is turned off, press any button to wake up the logger.
- While in the main menu use the up or down buttons ▲ ▼ to scroll until the cursor is pointing at **Timing**. Press enter ► to select.
- Scroll ▲ ▼ until the cursor is pointing at Time, Speed or Acceleration, press enter ► to select.
- Scroll ▲ ▼ buttons until the cursor is pointing at the required option, press enter ► to select.

Timing options are:

Time menu
Time at A
Time at A or B
Time from A to B
Period at A
Stopwatch A to A

Speed menu
Speed at A using:
• Double Interrupt card
• Picket fence
• Spoked pulley
Speed at A or B using:
• Single Interrupt card
3 Speeds at A or B using:
• Single Interrupt card
Speed from A to B
• Distance A to B
Speed at A then B using:
• Single Interrupt card

Acceleration menu
Acceleration at A using:
• Double Interrupt card
• Picket fence
• Spoked pulley
Acceleration A to B using:
• Single Interrupt card

- If Speed or Acceleration is selected scroll ▲ ▼ & select ► the apparatus you are using, scroll ▲ ▼ the list of dimensions and select ► the size used.
- When a signal change from the digital sensor/sensors is received, the timing measurement will be displayed on the LCD screen.

Time data is measured in seconds. Speed data is in metres per second (m/s).

Press the enter button ► to pause timing (a ► symbol will appear bottom right to show it's paused), press ► again to continue.

7. Press the stop ■ button to finish or cancel any pending timing event and then enter ► to confirm your choice.

The readings will be stored as a data set identifiable by the method and time and date the recording was started i.e. Timing 09/05/12 16:12:43. Up to 850 samples can be stored in one data set.

The contents of the data set can be

- Reviewed on V-Log - select **Review** from the main menu, use the ▲▼ buttons to locate the data set, press enter ► to select. Use the ▲▼ buttons to scroll through individual readings (see page 17).
- Downloaded to a computer by selecting **Retrieve ► Retrieve Remote** from the Home screen in the EasySense software. 

Other calculations can be performed on timing data by downloading to the EasySense software, then using the **Show Data as** function from the Settings menu in Timing.

Timing options

Time, Speed or Acceleration at A

Timing starts when the signal at input A changes and stops when the signal reverts back.

- With Light gates it will be the time it takes for an object to pass through the light beam.
- For a Push Switch it will be the length of time that the switch is kept depressed.
- For Timing mats it will be the length of time someone stands on the mat.

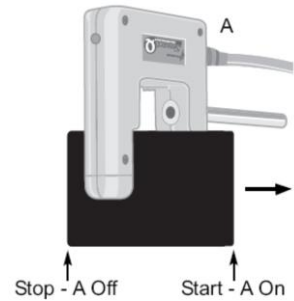

Using an interrupt card: Speed is calculated using the length of the interrupt card divided by the time taken for the card to pass through the sensor.

Using a double interrupt card: Average acceleration can be measured using a single light gate with a double interrupt card. Acceleration is calculated using the length of the segments on the double interrupt card.

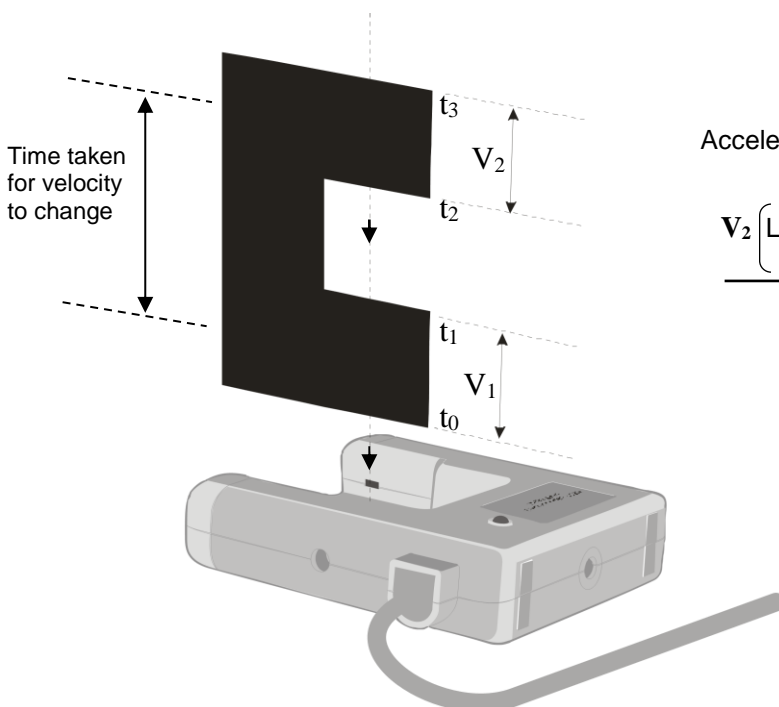

$$\text{Acceleration} = \frac{\text{Change in Velocity}}{\text{Time taken}}$$

$$\frac{V_2 \left(\frac{\text{Length of segment}}{\text{Time } (t_3 - t_2)} \right) - V_1 \left(\frac{\text{Length of segment}}{\text{Time } (t_1 - t_0)} \right)}{\text{Time taken}}$$

Using a Picket fence: Measurements shown are for instantaneous speed or acceleration i.e. it took this amount of time to travel this distance and the speed or acceleration was.

Speed at A
 = 0.61369 ms⁻¹ #2
 @time = 202.30468 s
 @distance = 0.050 m

To improve the accuracy of readings, an increment is automatically applied to a picket fence with a pitch length of less than 60 mm. This will mean that there are fewer readings than number of pitches on a fence.

Pitch length (l)	Readings taken with a pitch increment of:
80 mm	1 (80 x 1 = 80 mm)
60mm	1 (60 x 1 = 60 mm)
40 mm	2 (40 x 2 = 80 mm)
20 mm	4 (20 x 4 = 80 mm)
10 mm	5 (10 x 5 = 50 mm)

For example: (l) = 80 mm - readings taken with a pitch increment of 1 (80 mm).

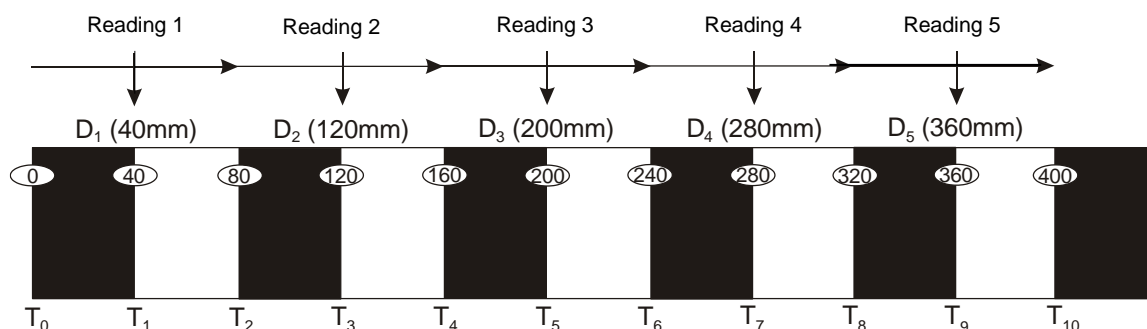

Reading 1 = $\frac{l}{T_2 - T_0}$	Reading 2 = $\frac{l}{T_4 - T_2}$	Reading 3 = $\frac{l}{T_6 - T_4}$	Reading 4 = $\frac{l}{T_8 - T_6}$	Reading 5 = $\frac{l}{T_{10} - T_8}$
-----------------------------------	-----------------------------------	-----------------------------------	-----------------------------------	--------------------------------------

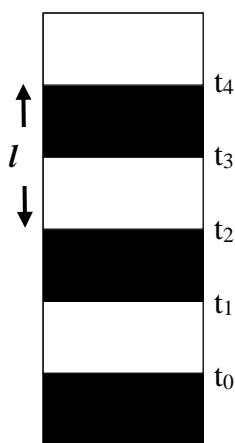

Instantaneous Acceleration is calculated using the change in Velocity of 2 pitches divided by the time taken for the velocity to change.

$$\frac{V_2 - V_1}{\frac{t_2 + t_3}{2} - \frac{t_0 + t_1}{2}}$$

Using a Spoked Pulley: Measurements shown are for instantaneous speed or acceleration i.e. it took this amount of time to travel this distance and the speed or acceleration was.

The measurement of the Data Harvest Spoked Pulley is pre-defined.

Set up the investigation but do not enter ► press enter until you are ready to take readings (the spokes on the pulley can easily interrupt the Light gate beam and create false results). When all is ready press ► for the recording to start (the ► symbol will disappear from the bottom line).

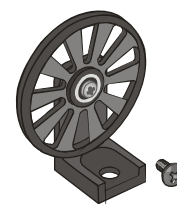

Time, Speed or Acceleration from A to B

Timing will start when a signal change is detected at sensor A and stops when the signal at B changes (so the measurement is for an object travelling from sensor A to sensor B).

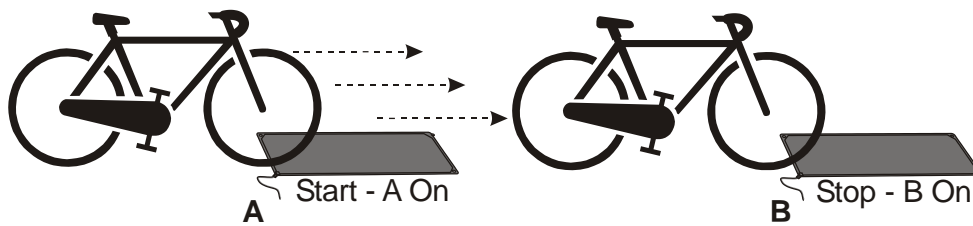

A single interrupt card measuring Acceleration = $\frac{\text{Change in Velocity}}{\text{Time taken}} = \frac{\text{Velocity at B} - \text{Velocity at A}}{\text{Time taken to travel from A to B}}$

Time A to A (stopwatch)

The time will start to be measured when the signal at input A changes (ON) and will continue until the signal at A changes again (ON) i.e. like a stopwatch.



Time or Speed at A or B

A measurement will be taken each time a signal change is detected at **either** sensor A **or** sensor B. The current measurement from A or B will be displayed on the LCD screen.

Speed at A or B	
A	0.61369 ms ⁻¹ n=2
B	0.32432 ms ⁻¹ n=4

Speed at A then B

Three measurements are recorded, they are:

1. Speed as it passed through Sensor A
2. Speed as it passed through Sensor B
3. Time to travel from A to B

Speed at A then B	
A	0.40453 ms ⁻¹ n=3
B	0.61261 ms ⁻¹
t	0.82318 s

Period at A

Start the pendulum swinging, and when it is moving freely press enter ► to start timing (the ► symbol will disappear from the bottom line).

The time will start to be measured when the pendulum first passes through the Light gate, it will ignore the second signal change (when the pendulum passes back through) and will stop at the third change (when the pendulum arrives back at the Light gate). The display will show the time for a complete period.

Press ► to pause timing (the ► symbol will reappear).

Period at A measures t₀ → t₄

- t₀ = Start (front edge of pendulum passes light gate – going forward)
- t₁ = ignored (back edge of pendulum passes light gate – going forward)
- t₂ = ignored (back edge of pendulum passes light gate – going back)
- t₃ = ignored (front edge of pendulum passes light gate – going back)
- t₄ = Stop (front edge of pendulum passes light gate – going forward)

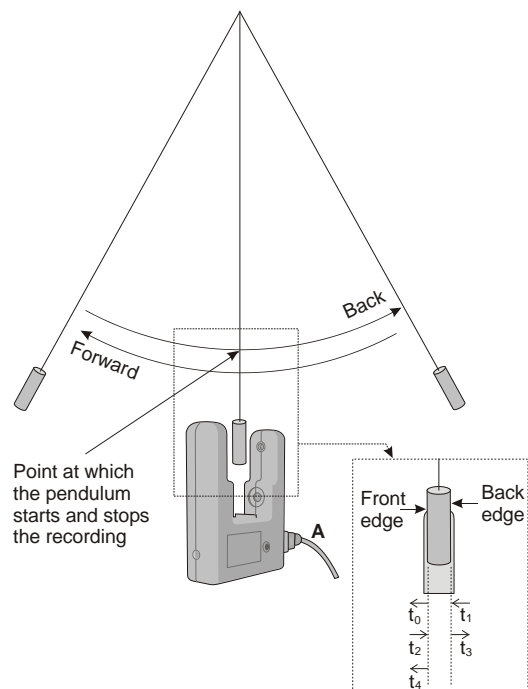

Counting

Counting is used to count events by using:

- One digital switch type sensor connected to either input A or input B
- Two digital switch type sensors connected to both input A and input B
- The up ▲ (A) or down ▼ (B) buttons on V-Log.

If plug-in sensors are connected, the logger will automatically count using input from those sensors.

Press ► to cycle through simple mathematical functions on the A and B data (A + B, A – B, B – A, Difference).

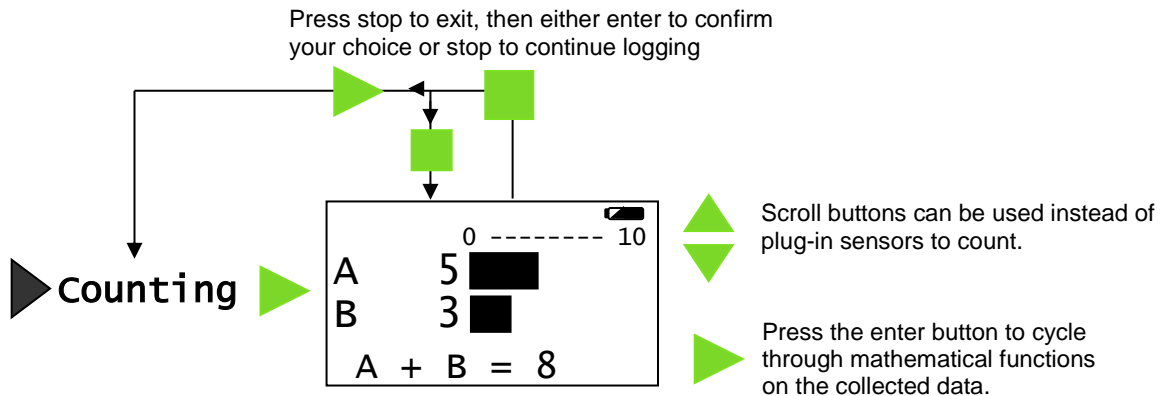

1. If you are using plug-in digital sensors connect them to input A and/or B. If the display is turned off, press any button to wake up the logger.
2. While in the main menu use the up or down buttons ▲ ▼ to scroll until the cursor is pointing at **Counting**. Press the enter button ► to select.

3. If you are using plug-in digital sensors each time the state of the sensor is changed to On e.g. by pressing a push switch, the number of counts will advanced by one.

If the scroll buttons on V-Log ▲ ▼ are used then the count will increase by one each time you press a button. You can use either one or both buttons e.g. use the ▲ button to count people entering a room and ▼ to count those leaving.

V-Log will display both the numeric value and show it as a bar graph. The bar maximum starts as 10, if the count goes above 10 it will increase to 20, then 50, 100, 250, 500, up to a maximum of 1,000.

Note: If V-Log goes into 'sleep' mode during logging, press any button to wake it up.

If counts are from both A and B pressing the enter button ► will cycle through simple calculations based on the counting data (e.g. A + B = 13, A – B = -3, B – A = 3, Difference = 3).

4. Press the stop ■ button to finish and then enter ► to confirm your choice.

The count will be stored as a data set identifiable by the method and time and date the recording was started e.g. Counting 09/05/12 16:12:43. Up to 999 samples can be stored in one data set.

The contents of the data set can be

- Reviewed on V-Log - select **Review** from the main menu, use the ▲ ▼ buttons to locate the data set, press enter ► to select.
- Downloaded to a computer by selecting Retrieve ► Retrieve Remote from the Home screen in the EasySense software. 

Review

You can use Review to view the readings stored in a data set. The most recently stored data is shown first.

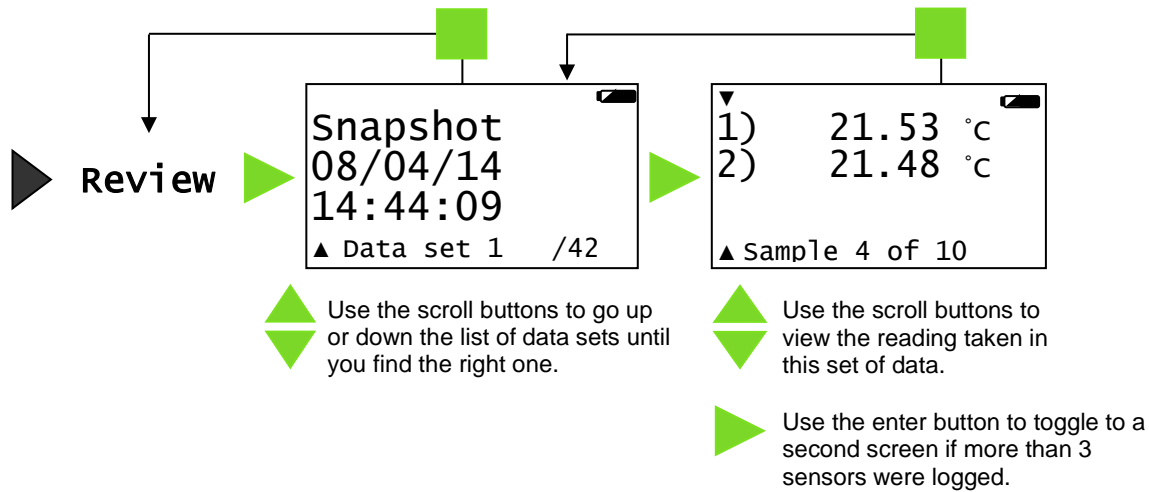

1. While in the main menu use the up or down buttons ▲ ▼ to scroll until the cursor is pointing at **Review**. Press the enter button ▶ to select.
2. Use the up and down buttons ▲ ▼ to scroll through the data sets, press enter ▶ when you locate the correct data set. The most recently stored data is shown first.
3. Use the up and down buttons ▲ ▼ to scroll through stored data points. If more than 3 sensors were logged, use the enter button ▶ to toggle to the second screen.
4. Press the stop ■ button to return to the list of data sets then ■ again to return to the main menu.

System

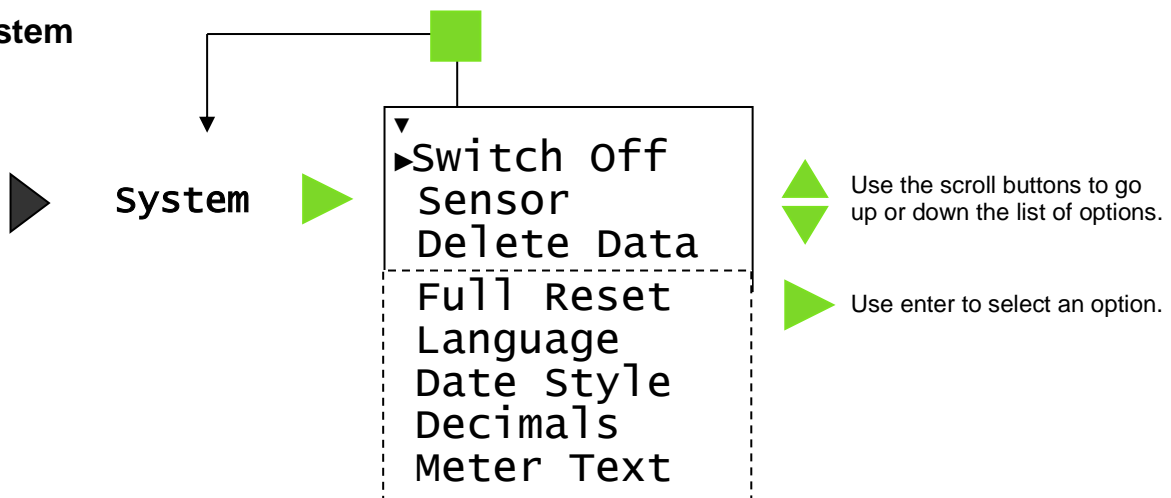

1. While in the main menu use the up or down buttons ▲ ▼ to scroll until the cursor is pointing at **System**. Press the enter button ▶ to select.
2. Use the up and down buttons ▲ ▼ to scroll the menu until the cursor is pointing to the appropriate system menu option. Press the enter ▶ button to select.

Switch Off

Used to send V-Log directly into low power (sleep mode), even when it's connected to a USB port. With the cursor pointing at **Switch Off** press the enter ▶ button to select.

Press any button to 'wake up' the logger.

Note: While operating on battery power V-Log automatically goes to low power (sleep) after a period of inactivity.

Sensor (changing range or turning on or off)

Note: This option is also available by pressing enter ► whilst in Meter mode.

Set range

Some built-in and plug in sensors have multiple ranges, to alter the selected range:

- Use the up or down buttons ▲▼ to move the cursor until it is pointing at the appropriate sensor and press enter ►.
- Use the ▲▼ buttons to move the cursor until it points at Set Range and press enter ►.

Note: If a sensor only has one range then only Turn Off will be available.

The cursor will indicate the current range selected. Use the up or down buttons (▲▼) to scroll the list until the cursor is pointing at the required range. Press enter ► to select.

- Press stop ■ twice to return to the System menu.

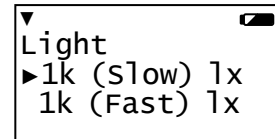
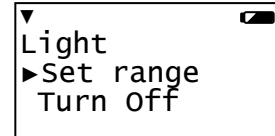

Turning a built-in sensor ON or OFF the display

Built-in sensors can be switched On or Off the display e.g. Sound, Pressure and Humidity switched off so only Light measurements are displayed.

- Use the up or down buttons ▲▼ to move the cursor until it is pointing at the appropriate sensor and press enter ►.
- Use the ▲▼ buttons to move the cursor until it points at Turn Off or Turn On and press enter ►.
- Press stop ■ to return to the System menu.

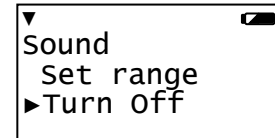

Notes:

- If you change a sensor's range or turn it on/off via the logger while connected to a computer, it may be necessary to select New in the software for these changes to be detected.
- If a Full Reset is performed it will automatically return all sensors to their default state.



Delete Data

Select whether to delete all or individual data sets.

- Delete all – press ► to confirm your decision or stop ■ to cancel.
- Choose data - use the up or down buttons ▲▼ to scroll through the data sets and when you find the data press enter ► to delete).

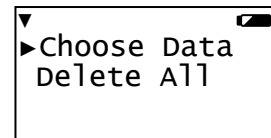

Full Reset

Please note: A full reset will erase all data sets!

A hard reset (see page 21) can be tried first if V-Log simply stops responding, a hard reset won't alter settings or erase data.

A full reset will:

- **Erase** all stored data sets.
- Automatically return any built-in sensors to their factory default setting (Sound On with dBA range, Light On with 1 kLux Slow range, Pressure On with kPa range, Humidity On).
- Return the date format to DD-MM-YY.
- Return decimals to On with a full stop format.
- Return language to its default.
- Any WiFi settings will not be altered (see page 28 for resetting WiFi setting).

- With the cursor pointing at **Full Reset** press the enter ► button to select.
- Select the enter button ► to confirm the reset or stop ■ to cancel and exit.
- Once done press enter ► to return to the main menu.

Language

Use to alter the selected language.

- With the cursor pointing at **Language** press the enter ► button to select.
The screen will show the language options (if any). The cursor will indicate the current language selected.
- If you wish to alter the choice use the scroll (▲▼) buttons to scroll the cursor until it is pointing at the preferred language and press the enter ► button to select.

Date Style

Use this option to alter the format of the date display (how you would like the date displayed) i.e. from a European to USA date format (DD-MM-YY to MM-DD-YY). The actual time and date is set automatically by the computers clock (see notes).

- With the cursor pointing at **Date Style** press the enter ► button to select.
- The cursor will indicate the current selection. If you wish to alter the choice use the ▲▼ buttons to scroll the cursor until it is pointing at the preferred style and press the enter ► button to select.

Note: V-Log's internal clock is set automatically by the computers clock (date and time) each time it is connected to the computer and the EasySense software is run. If the date or time on a data set is not correct, check the date/time settings on your computer.

Decimals

- **Turn decimals Off or On** - with the cursor pointing at **Turn Off** or **Turn On** press the enter ► button to alter the selection (from Off to On or vice versa).
- **To change the format** of the decimal separator from a full stop to a comma, scroll to **Format** and press enter ►. Scroll to the number displayed with a comma, press enter ► to select.

Meter Text

Use to choose whether the text height should be double or single height whilst logging in Meter mode.

With double height selected data from up to 4 sensors is visible on the screen (scroll to see more). If single height is selected then the data from up to 8 sensors is visible.

1)	23.9 °C
2)	20.5 °C
3)	24.1 °C
4)	15.6 °C
5)	50.9 dBA
6)	150 lx
7)	100.88 kPa
8)	35.9 %RH

Technical information

Selecting the sensor range

Some of the internal sensors in V-Log and some plug-in sensors have more than one range. Once a range has been selected it will be used until reselected.

The range of a sensor can be altered:

- In V-Log Meters (see page 7).
- In V-Log System (see page 18).
- Using Sensor Config in the EasySense software (Settings menu).
- Using New in the EasySense software (EasyLog, Graph, Pictogram, Snapshot, Counting mode).

Powering V-Log

EASYSSENSE V-Log can be powered by:

1. The USB port (whilst connected).
2. Its internal batteries (when charged).

Connect V-Log directly to a USB port on your computer*, or a USB mains charger**, or a powered USB hub***, using the USB cable supplied. A full charge can take up to 8 hours.

A battery charging symbol will be displayed on V-Log's screen while the logger is charging.

Notes:

- *Your computer must be turned on and not in sleep or standby mode; otherwise, the battery may drain instead of charge.
- ** USB mains charger that outputs 5 V at 1 A or more.
- ***V-Log can only be connected directly to a computers USB port or by using a **powered** USB hub. It will not work with an unpowered hub (V-Log requires an output current of 500 mA).
- An extension cable must be of a single direct port extension type.

While V-Log is accepting power or in WiFi or Bluetooth mode it will not operate auto switch off.

When used in WiFi mode it is recommended that V-Log is connected to a power supply as the power requirements are high, and will drain the battery quickly.

If using intending to use V-Log in Bluetooth mode powered by its battery, fully charge the battery before use e.g. leave to charge overnight for use in lessons the next day. When the battery is in good condition and fully charged it will power a Bluetooth connected V-Log for about 8 hours.

Batteries

V-Log is fitted with a rechargeable lithium-ion battery pack. Whenever V-Log is connected to the USB port on the computer, it will automatically re-charge the battery.

Lithium-ion batteries are 'memory-free' and prefer a partial rather than a full discharge. Constant partial discharges with frequent recharges will not cause any harm. Frequent full discharges should be avoided whenever possible.

Ideally V-log should be stored at about 40% or more charge. Do not store V-Log with its battery fully discharged or with sensors connected. Even when turned off (asleep), V-Log will use a small amount of current, and the battery will slowly discharge (some reserve charge is required to retain data and settings in memory). If V-Log is to be stored for lengthy periods without use then it's a good idea to recharge the battery every 6 – 8 weeks.

When its battery is in good condition and fully charged it will power V-Log in EasyLog or remote mode for a minimum of 41 days.

The speed at which a lithium-ion battery will age is governed by both its storage temperature (preferably less than 40°C) and state-of-charge. Ideally batteries should be replaced every 4 years. Eventually the battery pack will no longer deliver the stored energy and will need to be replaced. A fully charged battery that loses its charge quickly or a battery with symptoms of swelling or physical damage will demonstrate the need for replacement. When this happens, contact Data Harvest and request a battery replacement pack for **EASYSSENSE V-Log** – Product No. 5007.

Auto switch off

While battery powered V-Log will normally auto switch off (go into low power sleep mode) to reduce power consumption if more than two minutes have passed since any measurements have been taken or a button was pressed.

- If V-Log is accepting power or in WiFi or Bluetooth mode it will not operate auto switch off.
- V-Log will wake up when any button is pressed.
- While remote recording on battery power in EasyLog mode or after using Setup Remote, V-Log will stay awake until the interval between readings reaches 5 seconds or greater – at this point it will begin to use sleep mode between samples (waking up just in front of the sample time to allow the sensors to stabilise).

- While in Timing or Counting mode V-log does not operate auto switch off and will stay awake ready to take a measurement.

Internal Clock and Calender

V-log's internal clock will be updated automatically by the computers clock (date and time) each time it is connected to the computer and the EasySense software is run.

Note: If the date or time on a data set is not correct, check the date/time settings on your computer.

V-Log's memory

V-Log can store multiple data sets. The actual number will depend on the size of the data sets and that is dependent on how many sensors are connected and how many readings are taken.

Notes:

- System, Delete Data can be used to delete individual data sets or to delete them all.
- System, Full Reset erases all data sets and returns the logger back to its factory default settings.

Hard Reset

If V-Log fails to respond to the computer or a button press, carry out a hard reset.

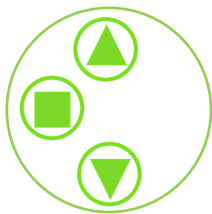

1. If necessary attach V-Log to USB power.
2. Press + + at the same time for a second and then release.

If the hard reset has been done correctly, the LCD will display **EASYSense V-Log** and the version number of its operating system before returning to the main menu.

Note: A Hard Reset does **not** erase any stored data sets but if a recording is interrupted by a reset, then the data being captured will not be stored

If V-Log still fails to respond apply a Full Reset or contact Product Support at Data Harvest.

Please provide details of:

- The computer platform it is being used with.
- The software version number
- A description of the problem being encountered

If possible, telephone from a location where you can operate V-Log with the computer.

Full Reset

A Full Reset will return V-Log back to the factory default settings.

WARNING! All data sets will be erased

- Scroll the menu to **System**, press enter to select. Scroll down to **Full Reset**. Press the enter button to select.
- Select enter to confirm this selection. Select enter to return to the System menu.

Specifications

- V-Log 8 only: 4 built-in sensors (Light, Sound, Humidity, Air Pressure)
- 4 *Smart Q* sensor inputs
- Timing inputs A & B
- 12 bit analogue sampling resolution
- Digital timing accuracy: 4 μ s

- Fastest logging speed (per channel): 50,000 samples per second [20 microsecond (μ s) between samples (50 kHz)]
- Firmware upgradeable
- Power specifications: 5 V at 500 mA or more
- Rechargeable battery pack: Lithium-ion 3.7 V, 1300 mAh (for replacement Order No. 5007)
- USB communication to PC V1.1 & V2.0 compatible
- Operating range: 0 - 40°C and 0 to 95%RH (non-condensing).
- Graphical LCD display (approx. 34 mm high x 68 mm wide - 75 mm diagonal).
- Weight of V-Log (logger only): approx. 248 g (+ 7 g WiFi module)
- External dimensions: approx. Height 44 mm max x Width 144 mm x Depth 102 mm.

WiFi specifications

V-Log WiFi is a wireless enabled data logger. It is classed as a mobile device and has a usable transmission range of 0.2 m to 10 m in open air.

- V-Log WiFi loggers produced prior to April 2016 are compatible with IEEE 802.11b.
V-Log WiFi loggers produced after April 2016 are compatible with IEEE 802.11n.
- Supports WPA-Personal (TKIP) and WPA2-Personal (AES) Security (802.11i)*
- Frequency Range: 2412-2462 MHz
- Channels supported: 1 to 11



*V-Log WiFi will automatically detect and use the required security protocol.

Hereby, Data Harvest Group Ltd., declares that V-Log WiFi is in compliance with the essential requirements and other relevant provisions of Directive 2014/53/EU.

A full copy of the Declaration of Conformity can be obtained by writing to the following address: Data Harvest Group Ltd., 1 Eden Court, Leighton Buzzard, Bedfordshire, LU7 4FY, UK.

Bluetooth specifications

Bluetooth 4.2 low energy radio, single mode compliant

Transmit (TX) power: 0 dBm

Receiver (RX) sensitivity: - 90 dBm

Usable transmission range: up to 10 m in open air

Frequency Range: 2.402 to 2.480 GHz operation

Care & Maintenance

- Clean with a damp cloth, do not immerse in water or detergent. V-Log is **not** waterproof.
- Do not subject to extreme heat or cold or leave in a location where it will get wet.
- Do not place your logger in an environment in which high humidity levels are possible as this may result in damage or malfunction
- If V-Log has been left in the cold, let it warm to near room temperature before waking it from sleep.
- Do not expose to direct sunlight for extended periods of time.
- Do not expose to temperatures greater than 60° C, e.g. near a heater or inside a car in hot weather.
- Do not store V-Log with its battery fully discharged. Ideally V-log should be stored at least **40% or more** state-of-charge. See page 20.

Updating EASYSense V-Log's Firmware

Occasionally Data Harvest may release updated firmware which will contain improvements or new features. Updates will be made available from the Data Harvest website.

To update the firmware of your **EASYSense** V-Log logger:

Step 1. Copy the English Firmware Update for V-Log onto the hard disc of your computer and run the .exe.

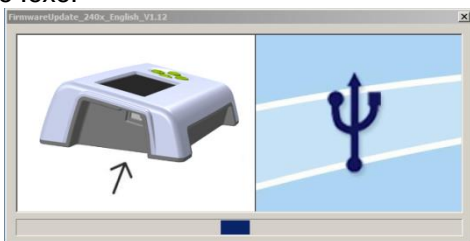

Step 2. Connect V-log to the computer using the USB cable.



A **tick** will indicate if the process was successful. Disconnect V-Log. To repeat this process, connect another V-log and click on the update window



Step 3. Wait for a few seconds. A progress bar will indicate V-Log is being programmed



A **cross** will indicate that an error occurred. Click on the update window to go back to the start screen and re-program.

Using V-Log connected via USB lead to Windows PC for the first time

Step 1:

Install the EasySense software, if it is not already on your computer. For details of how to install and operate this program, please refer to the instructions provided with the EasySense software.

V-Log requires **version 3.5** or above of the EasySense PC Windows software. (The version number can be verified in About from the Help menu).

Step 2:

Connect V-Log to the computer's USB port using the USB cable supplied. Windows will automatically detect a new device and install the drivers.

Step 3:

- Check that the LCD display on V-Log is displaying the main menu (EasyLog, Snapshot, Timing, Counting, Review, and System).

Note: In most circumstances V-log will **not** communicate with the PC if it is taking samples. If the LCD screen shows samples being taken, press the stop ■ button to finish recording.

- Open the EasySense software program. 

Step 4:

The first time the EasySense program is opened a 'Select Program Level' window will automatically open. Select a suitable user's level.

- Level 1 is aimed at 'start' level (e.g. up to 9 years old).
- Level 2 is aimed at 'mid' level (e.g. 9 – 15 years old)
- Level 3 is aimed at 'exam' level (e.g. 15 years plus).

Step 5:

An Interface option window will open.

- 1) If connecting an interface direct to a PC Windows computer select:

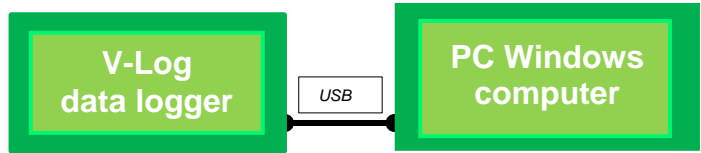

- Local Interface**
- Interface: **EasySense Range**
- USB Port** as the connection.
- If these settings will stay the same leave the 'Show at startup' box unticked.

If the box is ticked (enabled) the 'Select Interface' window will automatically open when you next start **EASYSense**, so you can check the selected method of connection is correct

- Click on OK. The program will save the selection.

The text at the top right of the **EASYSense** window will indicate that a Local Interface connection has been established.

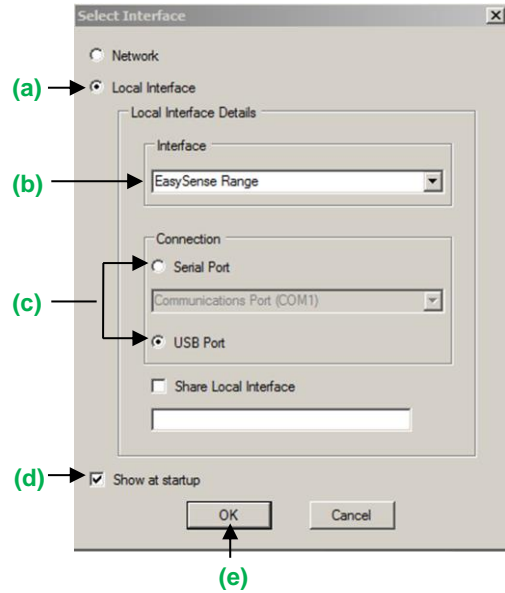
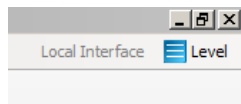

- 2) If simultaneously sharing data with other network users.

Data is captured in real-time by the Controller and instantly relayed to any Viewers that have made the connection to the Controller via the local network

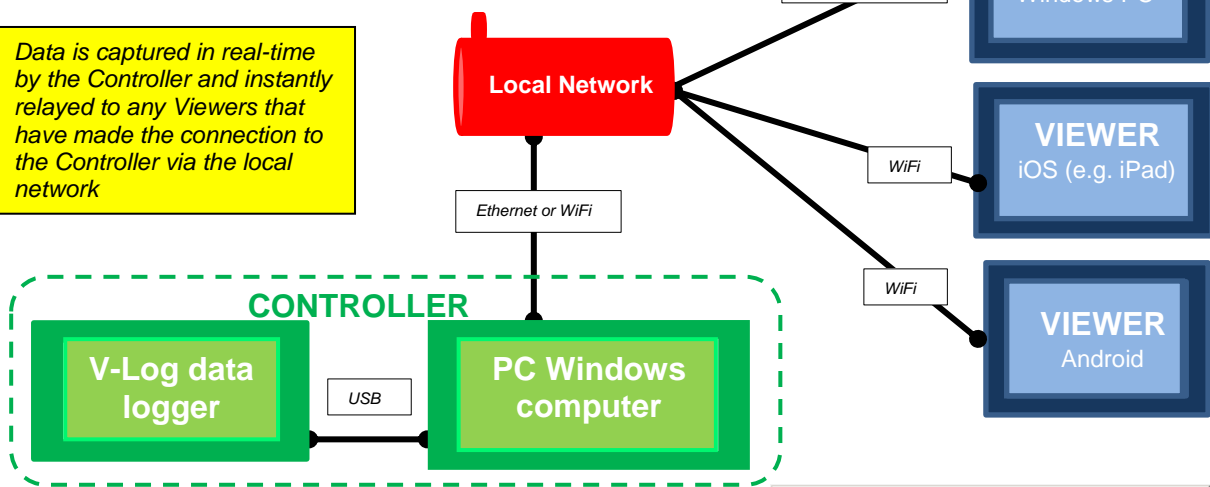

On the Windows computer acting as the **Controller** (interface connected to the computer) select

- Local Interface.**
- EasySense Range as the interface.
- USB Port** as the connection.
- Share Local Interface** to allow others network user's to connect as Viewers.

Note: Type in a more appropriate name for the controller computer if preferred.

- If the settings will always stay the same leave the 'Show at startup' box unticked.

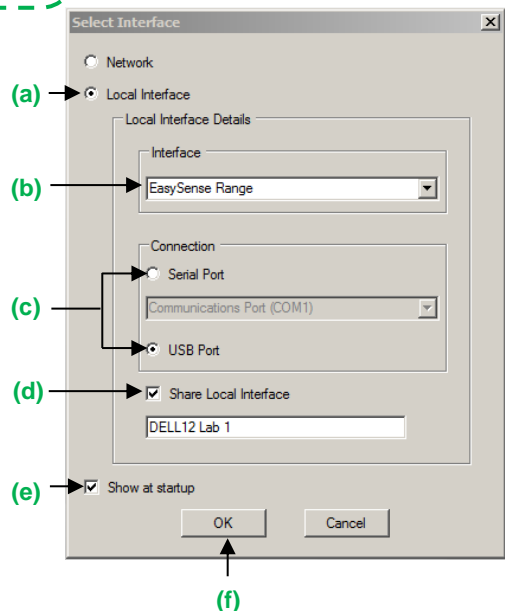

If the box is ticked (enabled) the 'Select Interface' window will automatically open when you next start EASYSense, so you can check that the selected method of connection is correct

- (f) Click on OK. The program will save the current selection.

The text top right of the EASYSense window will indicate that connection as the Controlling system has been established.

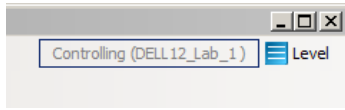

On the Windows computer that will be acting as a **Viewer** select

- (a) **Network**
- (b) If the 'Show at startup' box is ticked (enabled) this window will automatically open when you next start EASYSense, so you can check the selected method of connection is correct
- (c) Click on OK. The program will save the current selection.
- (d) Click on the **Not connected** text on the top right of the EASYSense window.

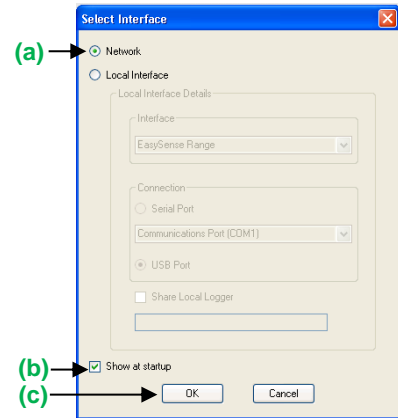

Select the computer acting as the Controller from the list of available devices, OK.

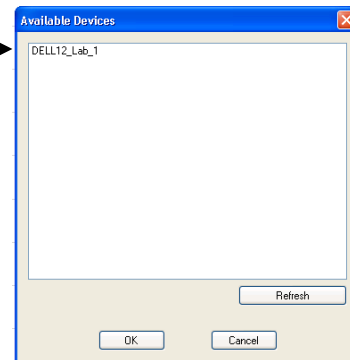
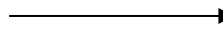

The text on the top right of the EASYSense window will indicate that connection as a Viewer has been established.

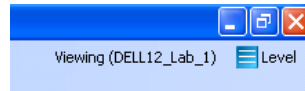

On an **iPad** that will be acting as a **Viewer**:

- (a) From Settings set Wi-Fi to the same network that the 'Controller' PC is connected to.
- (b) Open the EasySense iPad software, select the 'Not Connected' text at the bottom right of the screen and select the 'name' of the computer acting as the Controller from the list of devices.
- (c) The text will change to indicate that connection as a Viewer is established

On an **Android** that will be acting as a **Viewer**:

- (a) From Settings set WiFi to the same network that the 'Controller' PC is connected to.
- (b) Open the EasySense Android software, select the Connect icon (top right of screen) and select the 'name' of the computer acting as the Controller from the list of devices.
- (c) The text bottom right of screen will change to indicate that connection as a Viewer has been established

Step 6:

The Home screen will open. Select one of the experiment modes e.g. EasyLog, Pictogram, Meters, Snapshot, Counting or Timing.

V-Log in WiFi mode

It is recommended that V-Log is connected to USB power when used in WiFi mode as the power requirements are high, and will drain the battery quickly.



Connecting V-Log WiFi to a network

V-Log WiFi can operate in two different modes:

1. Connected to its own local network (Access Point)

V-Log WiFi is set to Access Point by default. In this mode the iPad connects to a network created by V-Log. This connection is typically used when not in range or able to access the school's network (perhaps on a field trip). While connected to V-Log in Access Point mode, the iPad will NOT be connected to any other school network resources, and therefore unable to access other items such as web pages, email, cloud storage, etc.

It is possible to have multiple V-Log WiFi loggers each creating their own separate network.

2. Connecting to an existing school's network (Infrastructure)

In this mode V-Log WiFi and the iPad connect to the same existing network. It has the advantage of allowing the iPad to remain connected to other resources delivered by the school network, such as web access, email, printing and cloud storage facilities, etc.

Note:

- V-Log WiFi loggers produced prior to April 2016 use 802.11**b**, ensure the WiFi network is **b** mode compatible.
If a **b** mode module is fitted the logger's WiFi label will just show WiFi and when you reset the logger it will flash 'with WiFi'.
- V-Log WiFi loggers produced after April 2016 use 802.11**n**, ensure the WiFi network is **n** mode compatible.
If an **n** mode module is fitted the logger's WiFi label will show WiFi**n** and when you reset the logger it will flash up 'with WiFi-n'

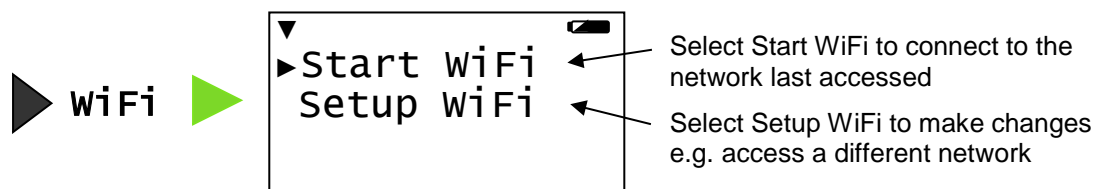

V-Log Access Point connection using the default settings

1. Select **WiFi**.
2. Select **Start WiFi**.

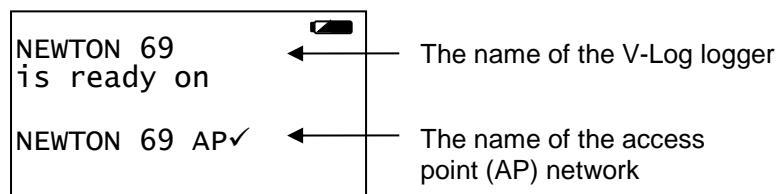

3. Connect the iPad or Android to the V-Log's Access Point network:
 - Select **Settings**.
 - Select the **Wi-Fi** link. Ensure Wi-Fi is ON.
 - Choose the **V-Log AP** network from the list of available networks. Wait for confirmation that the network has been joined e.g. a tick or it shows as Connected.
4. Start the **EasySense** App.
5. On an iPad tap on the status button 'Not Connected' (bottom right of the screen), on an Android tap on the connection icon (top right of the screen). Select the V-Log's name from the list.
6. The status will change to show that it is '**Controlling V-Log xx** or **Viewing V-Log xx**'.

To exit V-Log from WiFi mode select **■** and then **▶** to confirm.

Connecting V-Log to a school’s network (Infrastructure)

1. Select **WiFi**.
2. Select **Setup WiFi**.
3. Select **Scan for Networks**.
4. Once the scan has finished select the school’s network from the list that appears and **▶**.
5. If required enter the Key (the school network’s password), scroll to **✓** (bottom row right) then **▶**.
6. V-Log will show as connected to the school’s network.

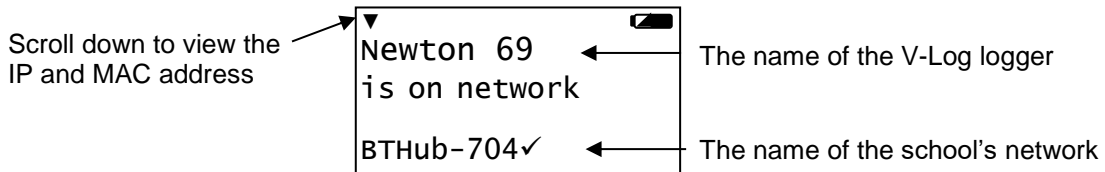
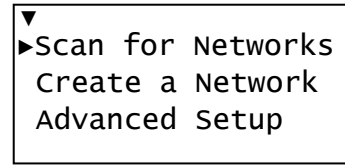

7. Connect the iPad to the school’s network. Start the **EasySense App**.
8. On an iPad tap on the status button ‘Not Connected’ (bottom right of the screen), on an Android tap on the connection icon (top right of the screen). Select the V-Log’s name from the list.

To exit V-Log from WiFi mode select **■** and then **▶** to confirm.

When you next V-Log in WiFi mode it will be set to connect to the school’s network so just select **WiFi** then **Start WiFi**.

It is possible to connect a number of V-Log WiFi loggers to the school network simultaneously, each with its own unique name. From the iPad select the required V-Log by choosing it from the list in the EasySense iPad software.

To connect back to an Access Point network

- Select **WiFi**, then **Setup WiFi**.
- Select **Create a Network**.
- To create/connect the Access Point network without making any changes select **Start a Network**.

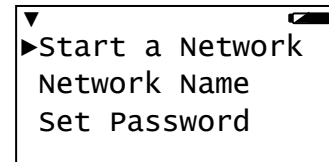

Open the EasySense App. On an iPad tap on the status button ‘Not Connected’ (bottom right of the screen), on an Android tap on the connection icon (top right of the screen). Select the V-Log’s name from the list.

To change the name of the Access Point network

- Select **WiFi**, **Setup WiFi**.
- Select **Create a Network**.
- Select **Network Name**.
- Use **■** to delete any characters from the existing name and enter the characters for the new name. Scroll to **✓** (bottom row right) then enter.

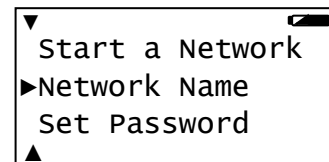

To encrypt the Access Point network

- Select **WiFi**, **Setup WiFi**.
- Select **Create a Network**.
- Select **Set Password**.
- Enter a suitable password (minimum of 8 characters). Scroll to **✓** (bottom row right) then enter.

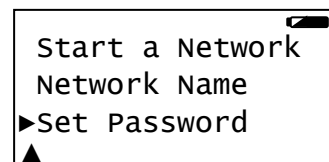

To make V-Log forget a known WiFi network

- Select **WiFi, Setup WiFi**.
- Select **Advanced Setup** and enter **DHG2020** as the password.
- Select **Forget a Network**.
- Select the network from the list, enter and confirm your choice.

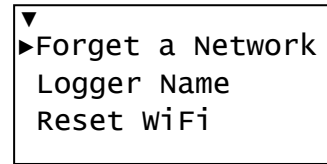

To change V-Log's name

- Select **WiFi, Setup WiFi**.
- Select **Advanced Setup** and enter **DHG2020** as the password.
- Select **Logger Name**.
- Use to delete any characters from the existing name and enter the characters for the new name. Scroll to **✓** (bottom row right) then enter.

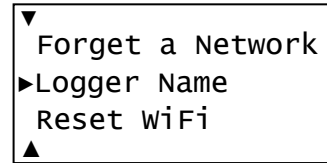

To reset WiFi to its default settings

- Select **WiFi, Setup WiFi**.
- Select **Advanced Setup** and enter the **DHG2020** as the password.
- Select **Reset WiFi**, enter and confirm your choice

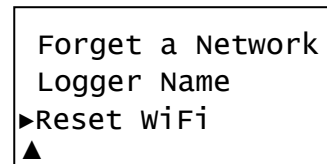

Using the on-screen keypad

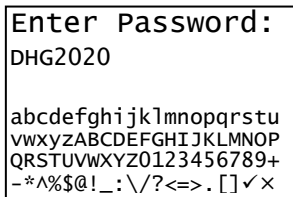

- Use the scroll buttons (**▲▼**) to go forward or back through the alphabet / numbers / symbols on the keyboard.
- Use enter **▶** to select / accept the symbol under the dark cursor.
- Use to delete a character.
- Move the cursor to the 'tick' **✓** symbol and press **▶** to accept the entered password.
- Move the cursor to the 'cross' **×** symbol and press **▶** to leave this screen with any characters entered to be rejected and ignored.

Connecting a group of iPads/Androids to a V-Log

It is possible for a group of devices to connect to one V-Log WiFi simultaneously to allow students to work collaboratively on a single experiment.

Note: Performance maybe impacted if lots of devices are connected to the same logger.

When connecting to V-Log, the first device (iPad, Android or Windows PC) to connect is given 'control' of the logger and will therefore be able to setup, start and stop the experiment. All subsequent devices that connect to the logger are given 'Viewer' status, they will see the set up changes made by the controller, and as data is captured it will appear in real time.

When the recording stops, all iPads and Androids will automatically save their own copy of the captured data in its internal memory. One iPad or Android cannot change or delete the data held on another device.

To leave a group, simply tap on the status button again to disconnect (iPad users this is bottom right of the screen, Android users top right of the screen).

When the controlling iPad/Android disconnects this will disconnect all the others. A new controlling iPad/Android is chosen by ensuring that it is the first to re-connect.

Setup WiFi menu

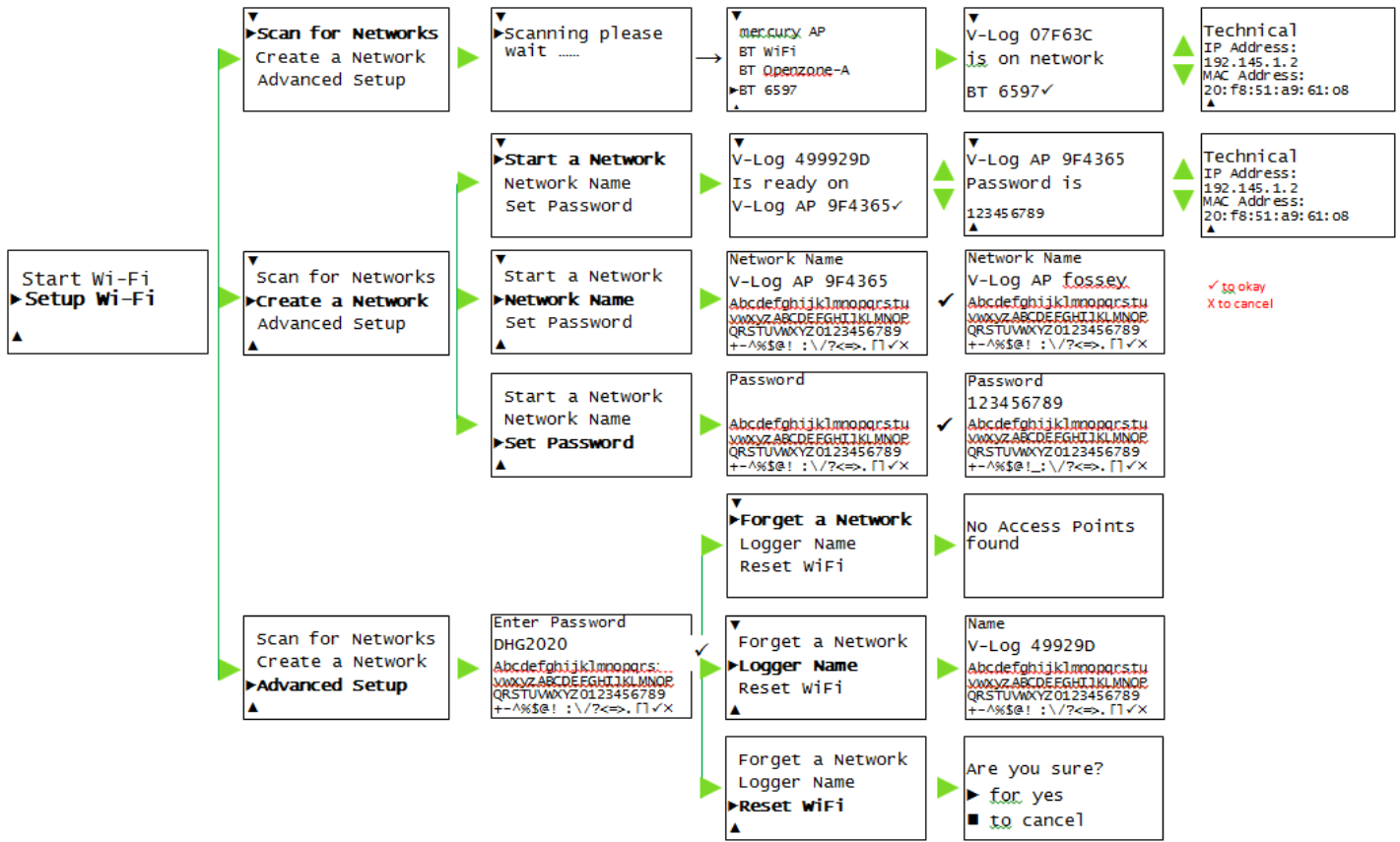

V-Log in Bluetooth mode



If V-Log has a Bluetooth board fitted it can be used in Bluetooth mode. If using V-Log battery powered in this mode, fully charge the battery before use e.g. leave to charge overnight for use in lessons the next day. When the battery is in good condition and fully charged it will power a Bluetooth connected V-Log for about 8 hours.

Note: V-Log stays awake while Bluetooth is turned on. Disconnect after use as the battery will continue to drain if V-Log is stored with Bluetooth still selected.

Ensure the firmware of V-Log is at least **V1.9** or higher.

Do **NOT** pair the devices (when paired V-Log will not be made available to the EasySense software).

When connecting to a Windows computer

EasySense software users:

- V3.10 or later of the EasySense Windows software must be installed.
- An operating system of Windows 7 or above is required.
- Connect a Bluetooth Smart USB adaptor (2070 or 2071) even if your computer has native Bluetooth 4 or BLE.



EasySense 2 software users:

- If the computer has built-in Bluetooth Low Energy (BLE) then a Bluetooth Smart USB adaptor is not required.

- Connect a 2070 or 2071 Bluetooth Smart USB adaptor to the USB port on the Windows computer. The adaptor is a plug and play device whose drivers should install automatically*.
- On V-Log scroll until the cursor points to Bluetooth then  to select. The screen will show the name of the logger.

- Open the EasySense software on the PC. 

- From **File, Interface** select **Bluetooth and Network**. OK.

Note: When first selected you may need to change Windows firewall settings to allow network access for this app.

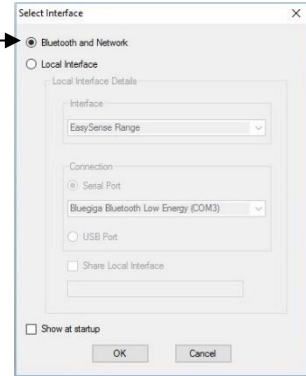

- Select the connection status text top right of the EasySense window.



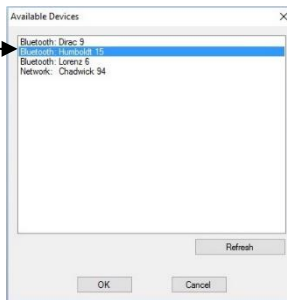

- Select the V-Log's name (as displayed on its screen) from the list.



- The connection status will change to show that it is '**Controlling xx** or **Viewing xx**' the logger.

A link symbol  on V-Log's screen will indicate connection to a computer.

When you've finished select the connection status icon in the EasySense software to disconnect then press  then  to confirm on V-Log.

* If auto install fails, download and unzip the drivers for the Bluetooth USB adaptor (Product 2070 or 2071) from the Data Harvest website. Open Device Manager, right click on the entry for the dongle (typically listed under Other devices) and select Update drivers. Select to 'Browse my computer' (install manually), locate and select the BLED112 directory. When installed the adaptor will be listed under the Ports (COM & LPT) section.

When connecting to a iPad or Android device



An iPad will need to support Bluetooth Low Energy (BLE) also known as Smart or 4 (iPad 3 or later or any iPad Mini). **V1.15** or later of the EasySense iPad software **must** be installed.

An Android will need to support Bluetooth Low Energy (BLE) / Smart – OS 4.4 or later. **V1.09** or later of the EasySense Android software **must** be installed.

Do **NOT** pair the devices (when paired V-Log will not be made available to the EasySense software).

- Check in **Settings** on the device that Bluetooth is On.
- Select Bluetooth on V-Log.
- Start the EasySense software.
- On an iPad tap on the 'Not Connected' text bottom right of the screen.
On the Android select the connect icon , top right of the screen
- Select the V-Log's name from the list.

The status will change to show that it is '**Controlling xx** or **Viewing xx**'.

When you've finished select the connection status icon in the EasySense software to disconnect, then press  then  to confirm on V-Log.

Limited warranty

For information about the terms of the product warranty, see the Data Harvest website at: <https://data-harvest.co.uk/warranty>

Note: Data Harvest products are designed for **educational** use and are not intended for use in industrial, medical or commercial applications.



WEEE (**W**aste **E**lectrical and **E**lectronic **E**quipment) Legislation

Data Harvest Group Ltd is fully compliant with WEEE legislation and is pleased to provide a disposal service for any of our products when their life expires. Simply return them to us clearly identified as 'life expired' and we will dispose of them for you.

FCC Details

This device complies with Part 15 of the FCC Rules. Operation is subject to the following two conditions: (1) this device may not cause harmful interference, and (2) this device must accept any interference received, including interference that may cause undesired operation.

**Data Harvest Group Ltd.,
1 Eden Court,
Leighton Buzzard,
Bedfordshire, LU7 4FY.**

**Tel: +44 (0)1525 373666
Fax: +44 (0)1525 851638**

**sales@data-harvest.co.uk
support@data-harvest.co.uk
www.data-harvest.co.uk**