



POWER ELECTRONICS LABORATORY

DL PEL



FPGA Based all-in-one Power Electronics and Electric Drives Lab

POWER ELECTRONICS INTRODUCTION

Power Electronics is the branch of Electronics that studies the devices, circuits, systems and procedures for the processing, control, and conversion of electrical energy.

Technological development in solid-state electronics and the semiconductor field has transformed power electronics providing active devices with higher switching speeds, and power handling at lower costs. The power electronic devices commonly found in the industry are Diodes, SCR, TRIAC, MOSFET, and IGBT. Their different attributes dictate how they are used in different applications, according to the type of input and output power: AC to DC, AC to AC, DC to DC, or DC to AC. This technology can be found in a wide range of settings impacting everyday life, from consumer electronics, industrial applications, transportation, telecommunications, power systems, to space technology.



DE LORENZO'S SOLUTION

Power Electronics can be defined as the application of solid-state electronics for the control and conversion of electrical power. The technological development in solid-state electronics and its integration with microcontroller technology has transformed power electronics from a static conversion technology to an essential element embedded in most of our electrical and electronic systems powering most of our everyday applications.

The PEL laboratory has been developed as a comprehensive hands-on training solution to study all the main devices and the power conversion techniques commonly used in the industry. It is divided into 5 main sections: AC to DC conversion (Rectifiers), AC to AC conversion (AC voltage controllers), DC to DC conversion (Choppers), DC to AC conversion (Inverters) and electrical drive applications for DC and AC motors.

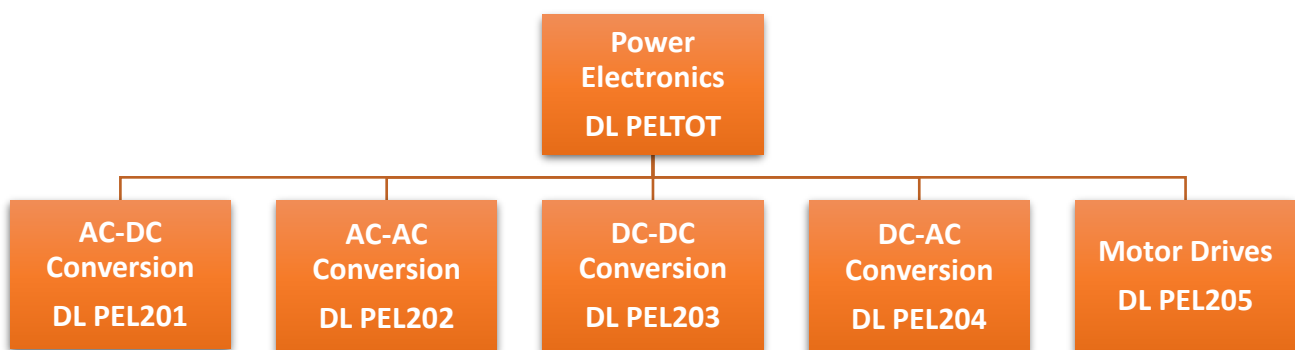

The digital control signals are generated using state of the art FPGA technology. Thanks to its high performance, a single reprogrammable data acquisition and control module gives great flexibility and reliability to reconfigure the laboratory according to the type of converter under study. It provides all the signalling while simultaneously acquiring the experiment data and waveforms.

The laboratory is monitored and controlled through an intuitive user interface that gives access to the main parameters of the system. The software will guide the student through the different proposed experiments with clear schematics, wiring diagrams and instructions providing feedback at each step. The morphing interface will adapt to the type of converter under study showing only the parameters that are available for the type of circuit. The different acquired signals can be visualized using a dedicated multichannel virtual oscilloscope, processed using the on-board math functions or exported and stored for further analysis.

Each configuration is ideal for 4 students to work simultaneously.



KEY CHARACTERISTICS

Modularity

- Reconfigurable lab composed of discrete elements.
- Industrial grade devices.

FPGA Based control and data acquisition

- The full system is controlled by an FPGA based data acquisition and control module.
- The NI Linux Real-Time processor combined with isolated I/Os, gives great flexibility and reliability to implement digitally controlled power converters.
- A PC user interface generates the control signals for the converter under study, controls its main parameters, and acquires and processes the characteristic waveforms using the powerful embedded mathematical tools.

Didactic approach

- All-in-one solution that gives the student a full view of power electronics.
- Gradual course that starts from the study of the power semiconductors and the main conversion strategies, to the study of their application as power supplies and drives.
- Hands-on, experiment-based, training platform.

Skills development

- Students interact with real industrial equipment.
- Study and implementation of the different power conversion techniques used in the industry.
- Study of main power electronics applications and electrical drives.
- The main controller SW is programmed using LabVIEW, a language widely used in the industry and academy.
- Development of analytical and troubleshooting skills through practical hands-on training.

Quality and Safety

- Made and designed in Italy using all the quality and safety standards following the CE directives for power devices:
 - CEI - EN 61010-1
 - CEI - EN 61439-1
 - CEI - EN 60335-1



DL PEL LABORATORY ARCHITECTURE

The laboratory is composed of a set of modules that provide a flexible and reconfigurable learning platform to study power electronics and its applications. Industrial-grade devices were integrated with dedicated drivers, isolation circuits and protections for maximum safety and reliability, providing a safe learning and experimentation environment. The laboratory was designed following CE directives for power devices, **CEI - EN 61010-1**, **CEI - EN 61439-1** and **CEI - EN 60335-1**.

The full system is controlled by a user-reconfigurable FPGA based data acquisition and control module that integrates a processor running in NI Linux Real-Time OS, giving great flexibility to implement digitally controlled power converters.

The control and acquisition module connects to the switching devices through a D-sub connector, resulting in less cable clutter, a faster setup and a more reliable connection avoiding wiring mistakes that could damage the equipment.

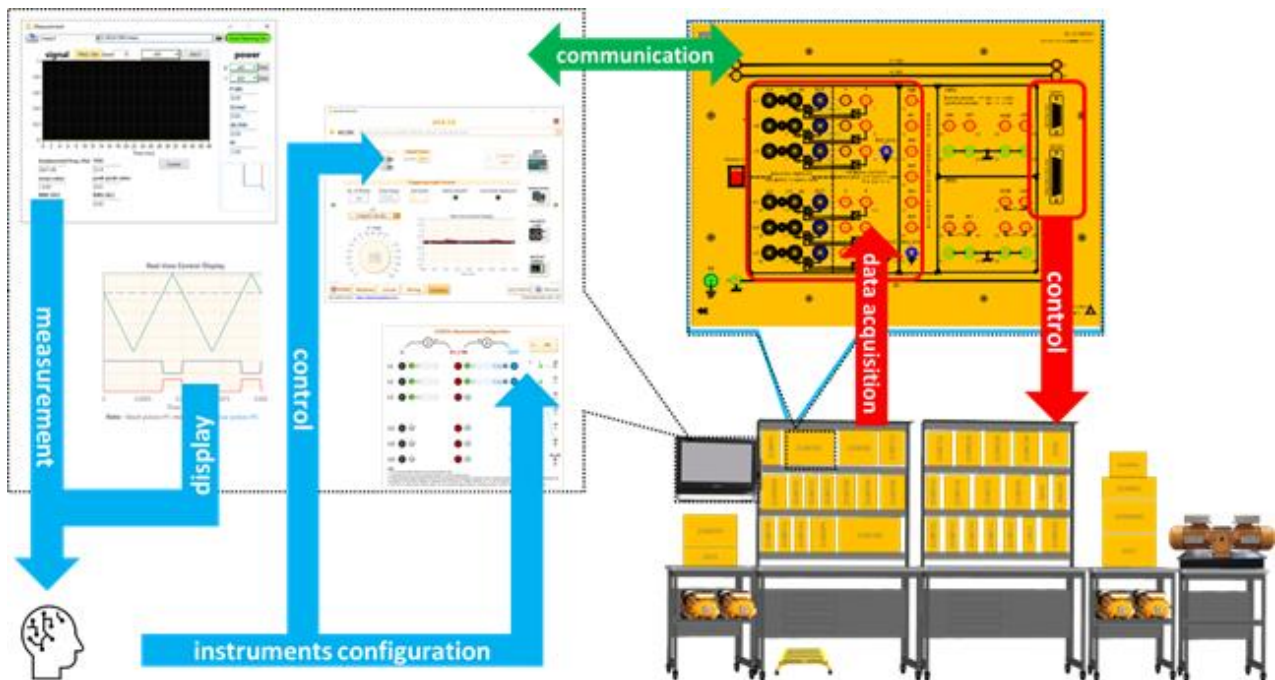

The software interface is programmed using LabVIEW, a language widely used in the industry and academy. The all-in-one user interface provides a clear view of signals being created to control the semiconductor devices and powerful visualization and mathematical tools to observe the resulting waveforms to study and simulate different controllers and power conversion strategies used in the industry.



CONTROL AND ACQUISITION SYSTEM

The control and acquisition module and the software interface together form the control centre of the lab. They perform the control of the different converters, acquire physical quantities, show warnings, and protect the system.

Control and acquisition module

It controls and monitors slave modules such as switching devices and frequency converter through the D-sub connectors. It also provides general purpose IOs to improve the system flexibility: 2 AIs, 2 AOs, 2 DIs and 2 DOs.

In addition to the control function, this module acts as a data acquisition device. It integrates 6 pairs of isolated voltage-current measurement inputs so users can observe the real-time waveforms and do quick signal processing of voltages and currents. The results are displayed through the software interface. The voltage-current measurement features wide input ranges, good bandwidth and isolation.

Compared to the conventional way using oscilloscope, the proposed solution has distinct advantages:

- No need for shunt resistors or current probes
- No need for differential high voltage probes
- No need for isolated power supply required by the oscilloscope
- No restriction of common ground shared by channels

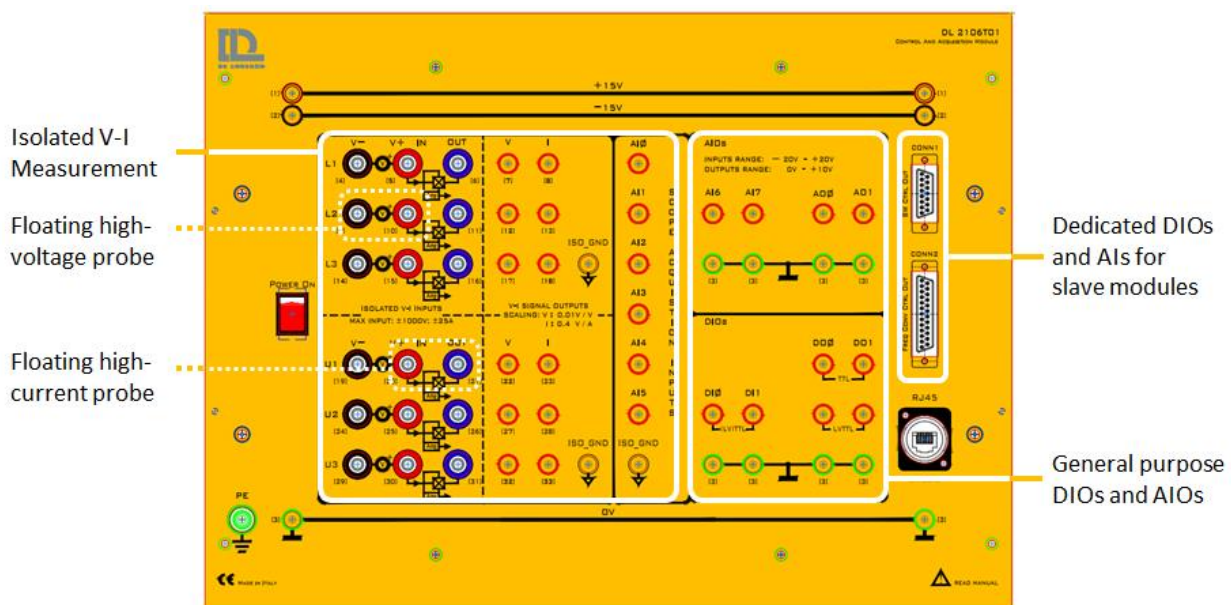

Maximum 9 signals of voltages and currents can be measured simultaneously. The signals connected to the front panel are well isolated from the controller for the purpose of reliability and anti-interference. It communicates with the control software via ethernet.

Software interface

The software interface creates a seamless connection between users and the Lab, enabling a smooth transition from preparation to completion of experiments. Realized in LabVIEW, it provides a user-friendly operation interface, conveys guidance information, translates user control commands for the FPGA-based control system, displays the measurement of the physical quantities, and supervises the operational status. This all-in-one software interface helps users focus on the experiment itself.

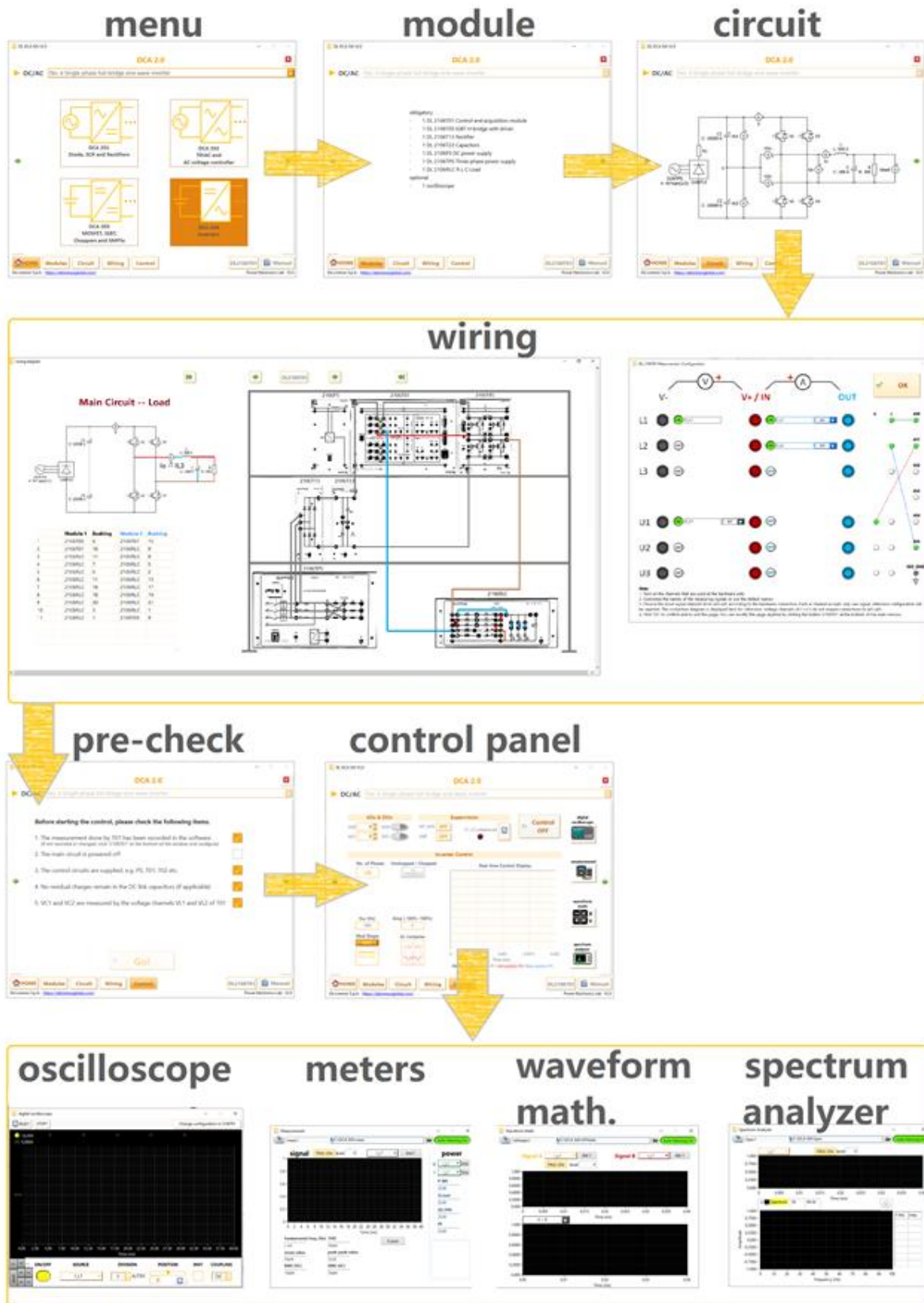



TRAINING OBJECTIVES

The Power Electronics trainer aims at undergraduate and graduate courses in the electrical engineering schools for the study of power converters and electrical drives. The laboratory equipment can be configured to create different exercises, which reinforces basic and advanced concepts in power electronics.

The main purpose is to study the principles of power semiconductors, power converters and their control methods, DC and AC machines, and electrical drives.

The entire system is fully configurable and can be tested under many conditions. Different experiments can be performed by rearranging the wiring and placement of the modules giving a lot of flexibility to simulate various converter topologies. Meanwhile, the control system provides classic control strategies for the converters and the electrical drive. The proposed exercises in different topics connect theoretical and practical concepts through hands-on experience.

SKILLS DEVELOPMENT



Basic

- Knowledge of power semiconductors
- Working principles of classic power converters under different conditions
- Classical control strategies for electrical drive
- Conduct measurement of high-voltage and high-current signals safely



Intermediate

- Modulation methods and control strategies for power converters
- Working principles of a complete power conversion system: frequency converter
- Knowledge of DC machines and induction machines
- Advanced control strategies for electrical drives
- PID tuning



Advanced

- Advanced power converters with their control and working principles
- Study on drivers of switching devices
- Analysis of signals in both time and frequency domain
- Expansion of application in your own environment



DL PEL201: AC-DC CONVERSION



The **DL PEL201** is a multipurpose bench to study the conversion from alternating current to direct current, using different configurations of non-controlled and controlled rectifiers, to later apply these concepts to drive AC and DC motor drives. The course is divided in two parts: the study of uncontrolled rectifiers using silicon diodes and the study of controlled rectifiers using Silicon Controlled Rectifiers (SCR). Its modular structure makes it easy to reconfigure the system to perform several experiments in various subjects such as uncontrolled diodes and static converter circuits, thyristors, single pulse/two-pulse midpoint converters, to name a few.

Experiments:

DIODES AND UNCONTROLLED RECTIFIERS

- *Silicon diode*
- *Uncontrolled single-phase half-wave rectifier*
- *Uncontrolled single-phase centre-tapped full-wave rectifier*
- *Uncontrolled single-phase bridge rectifier*
- *Uncontrolled three-phase half-wave rectifier*
- *Uncontrolled three-phase centre-tapped full-wave rectifier*
- *Uncontrolled three-phase bridge rectifier*



SCR AND CONTROLLED RECTIFIERS

- SCR
- *Controlled single-phase half-wave rectifier*
- *Controlled single-phase centre-tapped full-wave rectifier*
- *Half controlled single-phase bridge rectifiers*
- *Fully controlled single-phase bridge rectifier*
- *Controlled three-phase half-wave rectifier*
- *Controlled three-phase centre-tapped full-wave rectifier*
- *Dual 3-ph centre-tapped half-wave rectifier*
- *Half controlled three-phase bridge rectifier*
- *Fully controlled three-phase bridge rectifier*

Modules List DL PEL201:

CODE	DESCRIPTION	QTY
DL 2106T01	Control module	1
DL 2106T02	SCR driver	1
DL 2106T11	Silicon diode	1
DL 2106T12	Diode stack	1
DL 2106T14	SCR	1
DL 2106T15	SCR stack	1
DL 2106T21	Fuse box	2
DL 2106T25	1 Ω shunts	1
DL 2106PS	DC power supply	1
DL 2106TPS	3-ph power supply	1
DL 2106RLC	RLC load	1
DL 12B12	Battery	1
DL 2109D33	RMS meter	2



DL PEL202: AC-AC CONVERSION



The **DL PEL202** is a multipurpose bench to study the conversion from alternating current to alternating current. Its main fields of applications are in the control of temperature, lighting, and induction motors (with phase-control, on-off control and proportional time control). The course is divided into two sections: the first part studies thyristors and controlled AC/AC converters using power components as diodes, SCR and Triacs with two and six pulse control units and the second part shows a standard application with the study of a double-time constant light dimmer circuit consisting of Triac and Diac with fault simulation. Its modular structure makes it easy to reconfigure the system to perform several experiments in various subjects such as Triac, single-phase and three-phase controllers, to name a few.

Experiments:

THYRISTORS AND AC VOLTAGE CONTROLLER

- *TRIAC*
- *Fully controlled single-phase AC voltage controllers*
- *Fully controlled single-phase AC voltage controllers with TRIAC*
- *Half controlled single-phase AC voltage controllers*
- *Fully controlled 3-ph AC voltage controller*
- *Half controlled 3-ph AC voltage controller*
- *Two-phase controlled 3-ph AC voltage controller*



LIGHT DIMMER FAULT SIMULATOR

- *Phase control for the regulation of lighting with fault simulation.*
- *Double time-constant standard light dimmer circuit consisting of triac, diac, two control potentiometers, resistors and capacitors.*
- *20 faults can be switched on using switches located behind a cover. Typical faults: interruptions, short-circuit, faulty components and faulty design.*

Modules List DL PEL202:

CODE	DESCRIPTION	QTY
DL 2106T01	Control module	1
DL 2106T02	SCR driver	1
DL 2106T12	Diode stack	1
DL 2106T15	SCR stack	1
DL 2106T17	TRIAC	1
DL 2106T18	Light dimmer with fault simulator	1
DL 2106T21	Fuse box	1
DL 2106T25	1 Ω shunts	1
DL 2106PS	DC power supply	1
DL 2106TPS	3-ph power supply	1
DL 2106RLC	RLC load	1
DL 4236	Load manager	1
DL 2109D33	RMS meter	2
DL 2600TTI	Isolated transformer	1



DL PEL203: DC-DC CONVERSION



The **DL PEL203** is a multipurpose bench to study the conversion from direct current to direct current, and its main fields of applications such as DC power supplies and DC motor drives. The course is divided into two sections. The first part covers choppers and studies the conversion from fixed DC input to a variable DC output directly with the use of SCR, MOSFET and IGBT. The second section studies switching mode power supplies and analyzes the properties of the PWM control with the use of circuits as flyback and forward converters. Its modular structure makes it easy to reconfigure the system to perform several experiments in various subjects such as step-up/step-down converters, speed control of a DC motor, asymmetric half-bridge forward converter, to name a few.



Experiments

CHOPPERS

- *Switching devices (SCR with turn-off circuit, MOSFET, IGBT)*
- *Buck converter with SCR with turn-off circuit, PWM*
- *Buck converter with IGBT, PWM*
- *Buck converter with MOSFET, PWM*
- *Buck converter with MOSFET, PFM*
- *Buck converter with MOSFET, TPC*
- *Boost converter with IGBT, PWM*
- *Boost converter with IGBT, TPC*
- *Inverting converter with IGBT, PWM*

ISOLATED SWITCHING MODE POWER SUPPLY

- *Flyback converter with IGBT, PWM*
- *Forward converter with IGBT, PWM*
- *Asymmetric half-bridge forward converter with IGBT, PWM*

Modules List DL PEL203:

CODE	DESCRIPTION	QTY
DL 2106T01	Control module	1
DL 2106T02	SCR driver	1
DL 2106T03	MOSFET	1
DL 2106T04	IGBT	1
DL 2106T05	IGBT STACK	1
DL 2106T11	Silicon diode	4
DL 2106T13	Rectifier	1
DL 2106T16	SCR with turn-off circuit	1
DL 2106T21	Fuse box	1
DL 2106T22	EMI filter	1
DL 2106T23	Capacitors	1
DL 2106T24	Switching transformer	1
DL 2106T25	1 Ω shunts	1
DL 2106PS	DC power supply	1
DL 2106TPS	3-ph power supply	1
DL 2106RLC	RLC load	1
DL 2109D33	RMS meter	2
DL 2600TTI	Isolated transformer	1



DL PEL204: DC-AC CONVERSION



The **DL PEL204** is a multipurpose bench to study the conversion from direct current to alternating current, and its main fields of applications such as AC motor drives and AC uninterruptible power supplies. The trainer is designed to study the properties of the inverter with a Pulse Width Modulation control. Its modular structure makes it easy to reconfigure the system to perform several experiments in various subjects such as four-quadrant drive with cycloconverter, control of stator voltage with three-phase AC voltage controller, variable-frequency drive with space vector PWM (SVPWM), to name a few.



Experiments:

INVERTERS

Fundamentals of inverter

- 1-ph half-bridge inverter
- 1-ph bridge DC chopper, PWM

Single-phase inverter

- 1-ph bridge inverter, 180° conduction
- 1-ph bridge inverter, sinusoidal PWM
- 1-ph bridge inverter, square-wave PWM

Three-phase inverter

- 3-ph bridge inverter, 180° conduction
- 3-ph bridge inverter, sinusoidal PWM

Multi-level inverter

- 1-ph neutral point clamped (NPC) 5-level inverter, unchopped
- 1-ph neutral point clamped (NPC) 5-level inverter, PWM

Modules List DL PEL204:

CODE	DESCRIPTION	QTY
DL 2106T01	Control module	1
DL 2106T05	IGBT stack	2
DL 2106T12	Diode stack	1
DL 2106T13	Rectifier	1
DL 2106T21	Fuse box	1
DL 2106T22	EMI filter	1
DL 2106T23	Capacitors	1
DL 2106PS	DC power supply	1
DL 2106TPS	3-ph power supply	1
DL 2106RLC	RLC load	1
DL 2109D33	RMS meter	2
DL 2600TTI	Isolated transformer	1



DL PEL205: MOTOR DRIVES



The **DL PEL205** is a multipurpose bench for AC and DC motor drives where power electronics converters are studied as interfaces between input power and motors to control speed and position. The trainer dedicated to the study of different types of machine drives: the DC motors drives, AC slip-ring motor drives and AC squirrel cage motor drives, all of them with speed control. Its modular structure makes it easy to reconfigure the system to perform several experiments in various subjects such as single-phase full-bridge DC chopper/inverter (square wave or sine wave with PWM control), frequency converter, to name a few.

Experiments:

DC MOTOR DRIVE

DC motor drive by single-phase rectifiers

- Single-quadrant drive with 1-ph controlled rectifier
- Single-quadrant drive with 1-ph controlled rectifier for closed loop armature voltage control
- Single-quadrant drive with 1-ph controlled rectifier for closed loop armature voltage control with feedforward
- Single-quadrant drive with 1-ph controlled rectifier for single closed loop speed control
- Single-quadrant drive with 1-ph controlled rectifier for dual closed loop speed control
- Two-quadrant drive (I-IV) with 1-ph controlled rectifier
- Two-quadrant drive (I-III) with 1-ph controlled rectifier
- Two-quadrant drive (I-III) with 1-ph controlled rectifier for dual closed loop speed control
- Four-quadrant drive with 1-ph controlled rectifier
- Four-quadrant drive with 1-ph controlled rectifier for dual closed loop speed control

DC motor drive by three-phase rectifiers

- Single-quadrant drive with 3-ph controlled rectifier
- Single-quadrant drive with 3-ph controlled rectifier for dual closed loop speed control



CONSTANT FREQUENCY DRIVE – SLIP RING MOTOR

Stator voltage control

- Stator voltage control with variac
- Stator voltage control with AC voltage controller
- Speed control by stator voltage control with AC voltage controller

Rotor resistance control

- Rotor resistance control with rheostat
- Rotor resistance control with pulsed resistor
- Speed control by rotor resistance control with pulsed resistor
- Rotor resistance control with Scherbius static drive
- Speed control by rotor resistance control with Scherbius static drive

VARIABLE FREQUENCY DRIVE – SQUIRREL CAGE MOTOR

Frequency converter

- Operation of the frequency converter
- Input controlled rectifier
- Output inverter
- DC link brake chopper

Squirrel cage motor

- Preliminary investigation of the squirrel cage motor

Modulation methods of frequency converter

- Six-step modulation
- Square wave PWM
- Trapezoidal wave PWM
- Sinusoidal wave PWM (SPWM)
- Space vector PWM (SVPWM)

Induction motor control following U/f characteristic

- Motor magnetization for linear U/f characteristic
- Extra start magnetization
- IxR compensation
- Operation in standard converter setting
- Scaled-down operation in star connection

Speed control

- Slip compensation
- Closed loop speed control



Modules List DL PEL205:

CODE	DESCRIPTION	QTY
DL 2106T01	Control module	1
DL 2106T02	SCR driver	1
DL 2106T04	IGBT	1
DL 2106T06	Frequency converter	1
DL 2106T07	Three-phase power supply	1
DL 2106T12	Diode stack	1
DL 2106T15	SCR stack	2
DL 2106T21	Fuse box	2
DL 2106PS	DC power supply	1
DL 2106SPS	Single-phase power supply	1
DL 2106TPS	3-ph power supply	1
DL 2106RLC	RLC load	1
DL 2637	Stabilized power supply	1
DL 2109D33	RMS meter	2
DL 4236	Load manager	1
DL 2655	Variable 3 phase transformer	1
DL 2025DT	Tachometer	1
DL 10200A1	Shunt motor	1
DL 10250A1	Shunt generator	1
DL 10120A1	Slip-ring motor	1
DL 10120RA	Rotor rheostat	1
DL 10300P	Powder brake	1
DL 2006D	Load cell	1
DL 10300PAC	Brake control unit	1
DL 10400	Base frame	1
DL 10115A1	Squirrel cage motor	1
DL 10410	Flywheel	1
DL 2600TTI	Isolated transformer	1



DL PELTOT: POWER ELECTRONICS LABORATORY



The DEL PELTOT trainer has been designed to provide students with a fully comprehensive knowledge in power electronics systems, in a compact and flexible solution.

The laboratory is subdivided into 5 major study areas:

- AC-DC Conversion
- AC-AC Conversion
- DC-DC Conversion
- DC-AC Conversione
- Motor drivers



Modules List DL PELTOT

CODE	DESCRIPTION	QTY
DL 2106T01	Control module	1
DL 2106T02	SCR and TRIAC driver	1
DL 2106T03	Single MOSFET with driver	1
DL 2106T04	Single IGBT with driver	1
DL 2106T05	IGBT H-bridge with driver	2
DL 2106T06	Frequency converter	1
DL 2106T07	Three-phase power supply	1
DL 2106T11	Silicon diode	4
DL 2106T12	Diode stack	1
DL 2106T13	Three-phase diode bridge	1
DL 2106T14	SCR	1
DL 2106T15	SCR stack	2
DL 2106T16	SCR with turn-off circuit	1
DL 2106T17	TRIAC	1
DL 2106T18	Light dimmer - fault simulator	1
DL 2106T21	Fuse box	2
DL 2106T22	EMI filter	1
DL 2106T23	Capacitors	1
DL 2106T24	Switching transformer	1
DL 2106T25	1Ω shunts	1
DL 2106PS	DC power supply	1
DL 2106SPS	Single-phase power supply	1
DL 2106TPS	Three-phase power supply	1
DL 2106RLC	R-L-C load	1
DL 2637	Stabilized power supply	1
DL 2109D33	RMS meter	2
DL 4236	Load manager	1
DL 2655	Variable 3-phase transformer	1
DL 12B12	Battery	1
DL 2025DT	Tachometer	1
DL 10200A1	Shunt motor	1
DL 10250A1	Shunt Excited DC Generator	1
DL 10120A1	Slip-ring 3-phase motor	1
DL 10120RA	Rotor rheostat	1
DL 10300P	Powder brake	1
DL 2006D	Load cell	1
DL 10300PAC	Brake control unit	1
DL 10400	Base For Machines Coupling	1
DL 10115A1	Squirrel cage motor	1
DL 10410	Flywheel	1
DL 2600TTI	Isolated transformer	1