

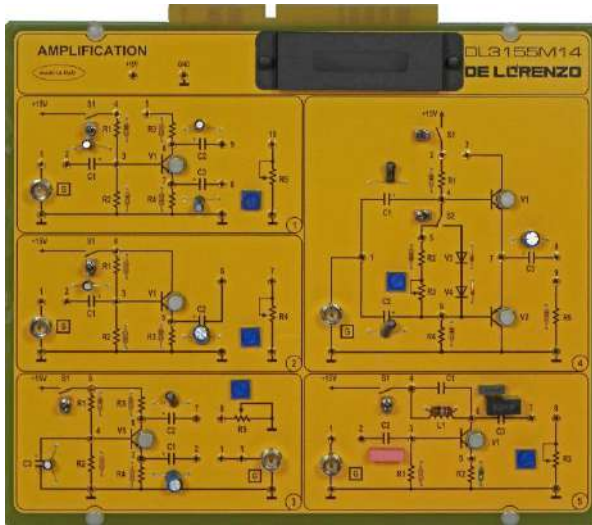

AMPLIFICATION



DL 3155M14

The design and construction of electronic circuits to solve practical problems is an essential technique in the fields of electronic engineering and computer engineering.

With this board the students can study the different configurations of transistor BJT, with emitter, collector and common base and also the configurations as a power amplifier in class B and in class C.

THEORETICAL TOPICS

- Linear amplification of current, voltage and power
- BJT amplifiers: EC, CC and BC configurations
- Thermal stability of a linear amplifier
- Static and dynamic load line
- Intermediate stage – final stage pre-amplifiers
- Power amplifiers in class A
- Power amplifiers in class B
- Power amplifiers in class C
- Fault simulation

CIRCUIT BLOCKS

- The common emitter amplifier
- The common collector amplifier
- The common base amplifier
- The push-pull power amplifier in class B
- The power amplifier tuned in class C

Complete with theoretical and practical manual.

Dimensions of the board: 297x260mm

CAI SOFTWARE:

Each board of the TIME system can be supplied complete with a Student Navigator software that allows students to perform their learning activities through a Personal Computer, without the need for any other documentation.

Ordering code: please add SW after the code of the board (i.e. DL 3155M14SW)

Required:

POWER SUPPLY NOT INCLUDED

Base frame with power supply (completed with connecting cables):

- DL 3155AL3 - Base frame with power supply and interface to pc and virtual instrumentation
- DL 3155AL2 - Base frame with power supply and interface to pc

Basic power supply (connecting cables not included):

- DL 2555ALG - DC power supply $\pm 5 \pm 15$ Vdc, 1A
- TL 3155AL2 - Connecting cables

Choosing this power supply, for the execution of the experiments, it is normally required the use of an oscilloscope and two multimeters.

